

TELEPHONE :
TAMWORTH 3641 (5 LINES)

STONEWARE L^{TD}

**: DOSTHILL :
TAMWORTH
: STAFFS :**



**STONEWARE PIPES
AND • BLUE BRICKS**

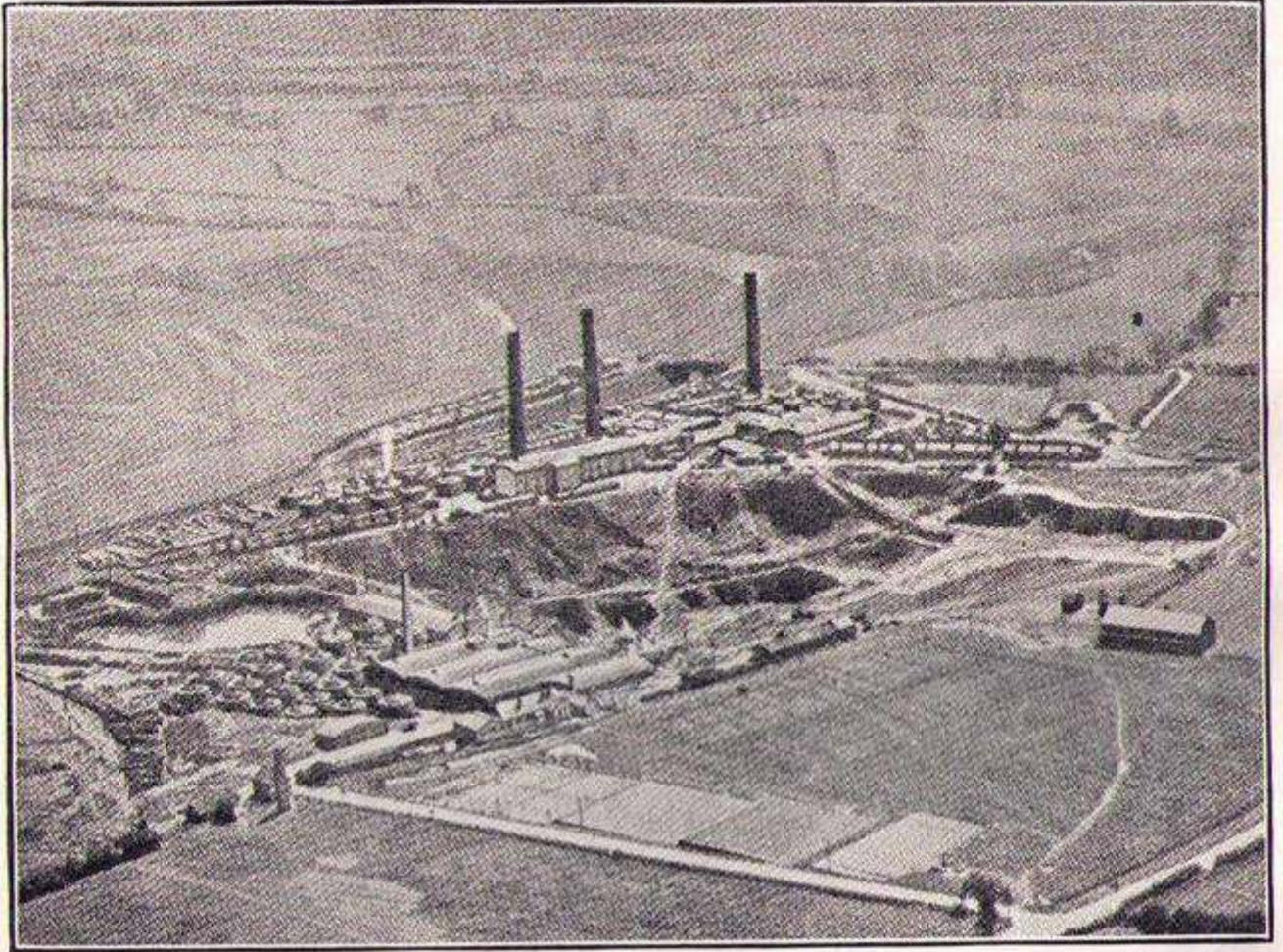

Aerial view of Works

Contractors to the War Office

Telegrams :
"STONEWARE, DOSTHILL"



Telephone :
3641-5 5 lines
TAMWORTH

Registered Trade Marks; "STOTAM" and "VORAM"

Stoneware LIMITED.

Manufacturers of

SANITARY PIPES, RUSTIC FACINGS, RED FACINGS, COMMON,
BLUE ENGINEERING AND BRINDLED BRICKS, FLUE LINERS,
AIR BRICKS, RIDGE TILES, SQUINTS, BULL NOSE, ETC., ETC.

DOSTHILL

Nr. TAMWORTH, Staffs.

Specialities:

Gullies, Interceptors and Fittings of all descriptions.
"Kether" Brand Silica Bricks "Zenith" Brand Furnace Bricks

Head Office : DOSTHILL, Nr. Tamworth, Staffs.

Registered Office:
47, TEMPLE ROW, BIRMINGHAM.
Telephone: 4000 Midland

London Address.
46, Victoria Street, Westminster, S.W. 1.
Telephone: Victoria 7834, 5441 and 5442

Nearest Passenger Station

WILNECOTE, L.M.R. 1½ miles
TAMWORTH " 3 "

INDEX

	Page		Page
Access Pipes, Bends, Junctions	25, 35, 47, 62	Dished Top for Clockface	57
,, Bends	35	,, ,, ,, Lane's pattern...	57
Air Bricks	71, 88	Double sockets	24
,, Extension—		Drain Chutes	49
"Deans Patent"	72, 88	Extension Pieces	63
Air Inlets	62, 68, 81	Filter Bed Tile	91
Angle Arm Gullies	43	Flue Linings	71
Anti Flood Gully—		Fresh Air Inlets	62, 68, 81
Deans Pattern	49, 51	Garden Edge Tiles	70, 95
Anti Flood Interceptor—		Gas Boiler Flue Bricks	95
Deans Pattern	49, 50	Gratings (Ironwork) ...	62, 63, 77-83
Armstrong Inspection Pipes,		Gullies (see also Street Gullies)	
Bends, Junctions	25	43, 54, 55, 57, 59, 63	
Bends	22, 26, 27, 62	Gullies Angle Arm	43
,, Access	25, 35	,, Anti flood Ball Valve—	
,, Channel	34, 35, 62	Deans Pattern	49, 51
,, Inspection	25, 35	Gully Connectors	29
,, Rest	22	Gullies Garage	56, 63
,, Sink	48	,, Grease	48, 56, 59, 63
Block Invert	69	,, Inspection	43, 46
,, Junction	69	,, Liverpool "D"	58
Bricks, Blue and Specials	69, 85-92	,, North Eastern	58
British Standard Specification ...	7-15	,, Raising Pieces for ...	47, 49
Bucket for Grease Gullies	48, 56, 81, 82	,, Reversible ...	44, 45, 47, 63
Butt Channels	70	,, Rust	55, 57
,, Pipes	71	,, Street	66-68
Cattle Troughs	69, 70	,, Untrapped	55, 63
Channel Blocks	36, 37, 38	,, with Inlets	43
Channels Half and three-quarter		,, Yard	54
Sections	33, 34, 35, 62, 70	Handhole Trap	58
Channels Bends	34, 35	Hand of Channel Goods	20
,, Bricks	91	Hassall's Joints	6
,, Butts	70	Hinged Gratings and Frames ...	79-83
,, Junctions	33	Hoppers, Round & Square	44, 45, 63
,, Pipes	33	Horse Mangers	70
,, Stop ends	70	Inlet Gullies	43, 54
,, Tapers	33	Inspection Pipes, Bends, Junctions	
Chimney Tops	73-76	25, 35	
Collar, Loose	24	,, Bends	35
Connectors for Gullies	29	,, Gully	43, 46
Copings	88, 89, 90	Interceptors — Ball Valve, Anti	
Deans Pattern Grease Traps	56, 59, 63	Flood, Deans pattern	49, 50
Dished Top for Gullies	46, 57	,, Brighton	40
,, ,, ,, Anti Splash	57	,, Buchan	41
		,, Croydon	41

INDEX — continued.

	Page		Page
Interceptors Deep Seal	40	Raising Pieces for Round and Square Gullies and Rainwater Shoes	47, 49, 62, 63
„ Kenon	41	Raising Pieces (Hoppers)	44, 45, 63
„ Rust	55, 57	Red and Blue Goods	85-95
„ Reverse Action	42, 62	Reversible Gullies ...	44, 45, 47, 63
„ Square End	40	Rest Bends	22
„ Weaver	41	Ridges	93, 94
„ Whole End	42	Rust Interceptors	55, 57
„ Winsor	41	Saddle Junctions	24
Invert Blocks	69	Sealing Plates ...	49, 62, 63, 80, 82
Joinder on Junction Branch	30	Section Channel Bends, half or three quarter	34, 35, 62
Junction Blocks	69	Sheffield Channel Blocks	36, 37, 38
Junctions	23, 62	Sink Pipes and Bends	48
„ Access	25	Special Joints	8
„ Caps	30	Step Irons	62, 81
„ Channel	33	Stoppers	24, 42, 62
„ Inspection	25	Street Gullies	66-68
„ Taper	29	„ „ Lancaster	67
„ Saddle	24	„ „ Moss Side Passage	57
„ Tumbling Bay	28	„ „ Radcliffe	67
Land Drain Pipe	71	„ „ Sharp	67
Level Invert Taper Pipe	62	„ „ Simpson	67
Lever Locking Stopper for Interceptor	42, 62	Syphons	42
Liverpool 'D' Gulley	58	Taper Channels	33
Loose Collar	24	Taper Junctions	29
Mangers	69, 70	Taper Pipes	24, 29, 62
Manhole Channels (see Channels)	—	Tested Pipes	9-15, 18
Manhole Covers	79, 80, 83	Traps	41, 42, 58
„ Step Irons	62, 81	„ Buchan	41
Measurement of Pipes with weights	16, 17	„ Croydon	41
Ministry of Works Designs ...	61-63	„ D.A.D.	42
Paving Bricks	92	„ Grease	48, 56, 59
Perforated Pipes	24	„ Handhole	58
Pipes	21, 71	„ P. and S.	42
„ Access	25, 47, 62	„ Rainwater	55
„ Butt	71	„ Syphon	42
„ Channel	33	„ Times	58
„ Inspection	25	„ Weaver	41
„ Land Drain	71	Troughs—Pig and Cattle	69, 70
„ Perforated	24	Tumbling Bay Junctions	28
„ Sink	48	Waste Receivers	55
„ Taper	24, 29, 62	Weights of pipes with measurements	16, 17, 21
„ Tested	9-15, 18	Weight Calculator for burned clay	28
Rainwater Shoes	47, 62	Yard Gullies	54
„ Trap	55		



HASSALL'S SINGLE-LINED JOINT with deep socket

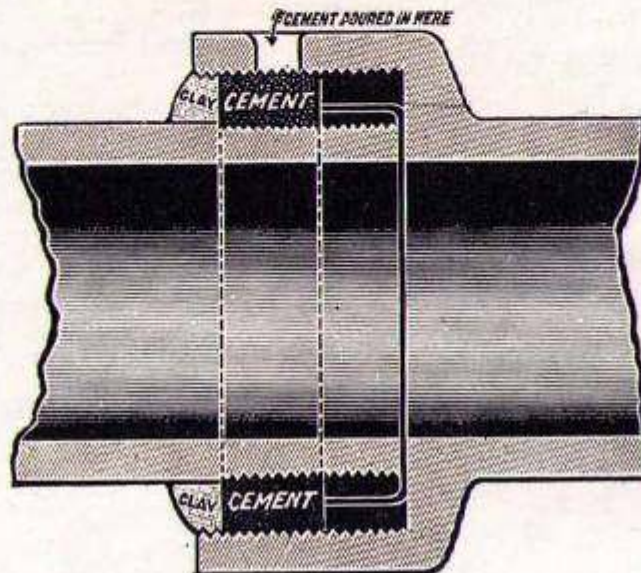

Pour holes are provided in the Socket, through which grouted cement is poured.

HASSALL'S DOUBLE-LINED JOINT

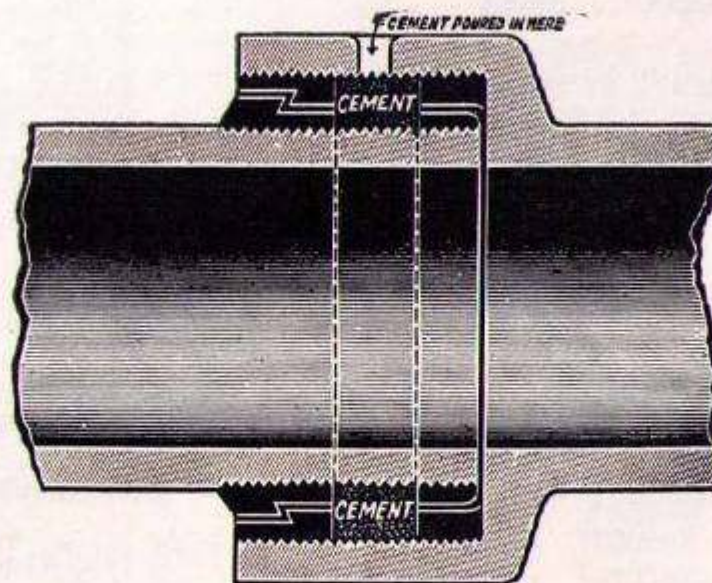

A treble seal is obtained with this joint.
TESTED PIPES CAN BE SUPPLIED TO ORDER.

GLAZED VITRIFIED CLAY DRAIN AND SEWER PIPES

FOREWORD

This British Standard supersedes but incorporates the former British Standard specification for salt glazed ware pipes last revised in 1952. A new specification has been rendered necessary by changes in the techniques of drainage design, and the development of new methods of glazing and manufacture.

With a completely new title and many alterations to the requirements, the specification is designed, along with related specifications, not only to bring clay drainage goods into line with the needs of modern practice, but also to bring into prominence qualities hitherto accepted without precise definition. The greatest change is to be found in the introduction of defined safe crushing test strengths for design purposes.

The scope clause has been widened to include pipes with or without sockets in order to permit the introduction of new types of joint and jointing materials into the industry without hindrance.

NOTE 1. Metric equivalents are given in Appendix D. The figures in British units are to be regarded as the standard. The metric conversions are approximate. More accurate conversions should be based on the tables in B.S.350, 'Conversion factors and tables'.

SPECIFICATION

Scope

1. This British Standard specifies the requirements for the following glazed vitrified clay pipes and fittings with or without sockets.

Pipes. Straight pipes.

Fittings. Taper pipes, concentric and level invert (eccentric)

Bends

Taper bends

Junctions

Channels, straight and taper, half-section

Channel bends, half-section

Channel junctions, half-section.

Description and Marking

2. Every article manufactured and supplied in accordance with this specification shall be described as 'British Standard' and shall be marked:

(i) With the name or trade mark of the manufacturer legibly impressed upon it before firing.

(ii) With the licence number of the manufacturer and the British Standard Number, B.S. 65/1963.

(iii) With the certification mark of the Institution as shown below, which mark shall have been indelibly stencilled or stamped in black thereon before despatch.

In addition to the above marking every article complying with the higher crushing strength requirements of Clause 10 shall be marked with the word EXTRA. If, at the request of the purchaser, any article shall have been hydraulically tested in accordance with Clause 12 the word TESTED shall be stencilled or stamped thereon.

NOTE. The mark B.S. 65/1963 on the product is a claim by the manufacturer that it complies with the requirements of the standard.

The British Standards Institution is the owner of the registered certification trade mark shown below. This mark can be used only by manufacturers licensed under the certification mark scheme operated by the B.S.I. The presence of this mark on a product is an assurance that the goods have been produced to comply with the requirements of the British Standard under a system of supervision, control and testing operated during manufacture and including periodical inspections at the manufacturer's works in accordance with the certification mark scheme of the B.S.I.

Further particulars of the terms of licence may be obtained from the Director, British Standards Institution, 2 Park Street, London, W.1.



Materials and Manufacture

3. The clay and glaze used in the manufacture of British Standard glazed vitrified clay pipes and fittings shall be such that when shaped, glazed and fired the product shall have the following characteristics:

- (i) Adequate structural strength—Clauses 10 and 12.
- (ii) High resistance to chemical attack—Clause 13.
- (iii) Permanently low water absorption—Clause 11.
- (iv) A uniformly smooth glazed inner surface—Clause 4.
- (v) High resistance to abrasion.

General Quality and Glazing

4. All pipes and fittings shall be sound and free from visible defects such as would impair their efficiency, and shall give a sharp clear note when tapped with a light weight hammer.

The interior surface of the pipes and fittings shall be glazed. Glaze shall not be required on the outside surface of the barrel, nor on the inside or outside of the socket, but if present, it shall not effect compliance with this standard.

The glaze shall be either:

- a. salt glaze, obtained by the action of common salt, compounds of sodium, borax, boric acid or a combination of these during the firing process
- or b. ceramic glaze consisting of suitable glazing material applied prior to firing.

Dimensions and Tolerances

5. a. Barrels. (See Table 1.)

(i) The internal diameter of the barrel of a pipe or fitting shall deviate nowhere from the nominal internal diameter given in Column 1 by more than the tolerance given in Column 2.

(ii) The mean thickness of the barrel shall be not less than the mean thickness shown in Column 3, such mean thickness of any individual barrel being ascertained by adding the measured least thickness (not in a groove) to the greatest thickness and dividing the sum by two.

(iii) The difference between the measured least thickness and the greatest mentioned above shall not exceed the amounts given in Column 4.

TABLE 1. DIMENSIONS AND TOLERANCES OF BARRELS

Nominal internal diameter	Tolerance in diameter (see Subclause 5a (i) above)	Minimum mean thickness (see Subclause 5a(ii) above). (A) in Fig. 1	Permissible variation in thickness (see Subclause 5a(iii) above)
in	in	in	in
3	$\frac{1}{8}$	$\frac{7}{16}$	$\frac{1}{16}$
4	$\frac{1}{8}$	$\frac{1}{2}$	$\frac{1}{16}$
5	$\frac{3}{16}$	$\frac{9}{16}$	$\frac{1}{16}$
6	$\frac{3}{16}$	$\frac{5}{8}$	$\frac{1}{16}$
7	$\frac{3}{16}$	$1\frac{1}{16}$	$\frac{1}{16}$
8	$\frac{1}{4}$	$1\frac{1}{16}$	$\frac{1}{16}$
9	$\frac{1}{4}$	$\frac{3}{4}$	$\frac{1}{16}$
10	$\frac{5}{16}$	$1\frac{3}{16}$	$\frac{1}{16}$
12	$\frac{5}{16}$	1	$\frac{1}{16}$
15	$\frac{3}{8}$	$1\frac{1}{4}$	$\frac{3}{32}$
18	$\frac{3}{8}$	$1\frac{1}{2}$	$\frac{3}{32}$
21	$\frac{1}{2}$	$1\frac{5}{8}$	$\frac{1}{8}$
24	$\frac{1}{2}$	$1\frac{3}{4}$	$\frac{1}{8}$
27	$\frac{3}{4}$	$1\frac{7}{8}$	$\frac{1}{8}$
30	1	2	$\frac{1}{8}$
36	1	$2\frac{1}{2}$	$\frac{1}{8}$

The spigots of pipes and fittings having grooved or roughened sockets may be grooved circumferentially or roughened and the depth of such grooves or roughening not to be protected by a socket shall be not more than 1/16 in.

b. Sockets. Sockets when present shall be one of two types, either:

Type 1. For use with manufacturers' special or flexible joints; or

Type 2. Grooved or roughened, for use with customers' selected jointing materials.

NOTE. Spigots and sockets of Type 1 not having other jointing materials attached may be used with customers' selected jointing materials.

Type 1. The design of sockets of Type 1 and the tolerances for both spigot and socket dimensions depend on the joint selected. The test pressure and the angular and axial straight movements which the joint will tolerate under that pressure without loss of watertightness, shall be stated by the manufacturer. The requirements for the thickness of the socket are the same as those for the barrel except for special provisions required for the joint.

Type 2. The interior of the sockets of Type 2 (see Fig. 1) shall be conical having a minimum taper of 1/16 in. measured on the diameter, per inch of length (i.e. 1 in 32), thus the diameter of a socket 2 inches deep will be at least $\frac{1}{8}$ inch greater at the top than at the bottom. The depth of such sockets shall be in accordance with Table 2. The width of the shoulder (C) of such a socket of any individual pipe or fitting shall exceed the mean thickness of the barrel (A) by not less than the figures given in Column 3 of Table 2. Such socket may be grooved circumferentially or roughened inside and the depth of such grooves or roughening shall be not more than 25 per cent of the minimum specified mean wall thickness of the barrel, subject to a maximum depth of $\frac{1}{4}$ in. The requirements for the thickness of the socket are the same as those for the barrel.

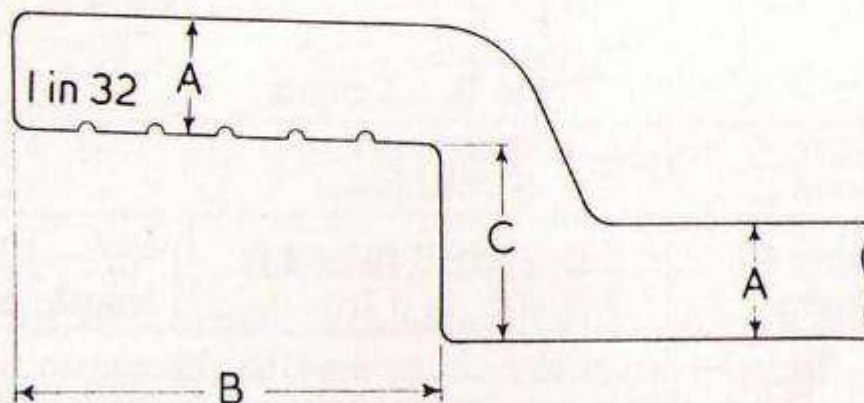

Fig. 1. Section of socket, Type 2

Table 2. Dimensions of Sockets (Type 2) (See Fig. 1)

Nominal internal diameter	Minimum internal depth of socket (B)	Minimum excess shoulder measurement (C-A)
in. 3	in. 2	in. $\frac{5}{16}$
4	2	$\frac{3}{8}$
5	$2\frac{1}{4}$	$\frac{7}{16}$
6	$2\frac{1}{4}$	$\frac{7}{16}$
7	$2\frac{1}{4}$	$\frac{7}{16}$
8	$2\frac{1}{2}$	$1\frac{1}{2}$
9	$2\frac{1}{2}$	$1\frac{1}{2}$
10	$2\frac{3}{4}$	$1\frac{5}{8}$
12	$2\frac{3}{4}$	$1\frac{5}{8}$
15	3	$1\frac{5}{8}$
18	3	$1\frac{5}{8}$
21	$3\frac{1}{4}$	$1\frac{3}{4}$
24	$3\frac{1}{2}$	$1\frac{3}{4}$
27	$3\frac{1}{2}$	$1\frac{3}{4}$
30	$3\frac{1}{2}$	$1\frac{3}{4}$
36	$3\frac{1}{2}$	1

Length of Straight Pipes and Channels

6. The lengths of straight pipes and half-section channels, exclusive of the internal depth of the socket shall normally be as specified in Table 3.

Table 3. Length

Internal diameter of pipe or channel	Length excluding depth of socket	Permissible variation
Up to and including 8 in	2 ft, $2\frac{1}{2}$ ft, 3 ft, or 4 ft	} $\pm \frac{1}{8}$ in per ft of length in all cases
9 in to 36 in inclusive	3 ft, 4 ft, or 5 ft	

Pipes of lengths other than the above may be deemed to comply with this specification provided that such other lengths have been agreed by the purchaser.

Permissible Deviation from Straightness

7. The permissible deviation from straightness of the barrel of a pipe shall be $1/16$ in. per 6 in. of length, less $1/16$ in.

Dimensions of Fittings

8. The requirements for the thickness of fittings shall be the same as those for the pipes with which they will be used.

The dimensions of fittings given in Figs. 3-16 and the related tables shall be regarded as indicative only and accurate compliance is not required.

The figures show sockets of Type 2 only. The form of Type 1 sockets depends on the type of joint.

Taper pipes and half-section taper channels may be ordered in any normal combination of diameters, including reverse tapers. The other dimensions shall be within the limits given in Tables 1, 2 and 3.

Definitions of Right and Left Hand Channel Fittings

9. A right hand channel fitting is such that when viewed against the direction of flow the arm of a junction, or the socket of a bend etc., projects to the right (Fig. 2). A left hand channel fitting is such that when viewed as above, the arm or socket projects to the left.

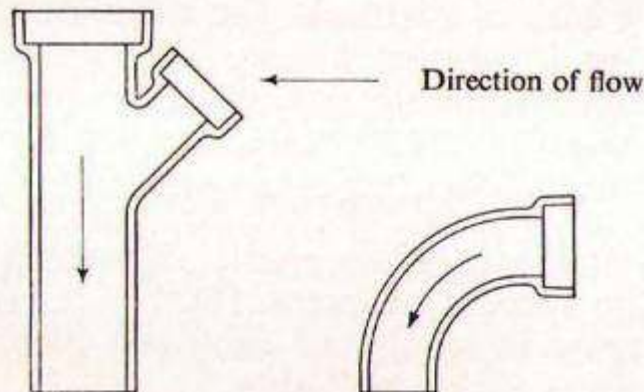

Fig. 2. Right hand fittings

Fig. 2. Right hand fittings

Crushing Strength

10. **Safe crushing test strength.** When tested along the full length of the pipe barrel from shoulder to spigot in accordance with Appendix A, the pipe tested shall withstand the intensity of loading appropriate to its size and class specified in Table 4, and this strength shall be called the safe crushing test strength.

Table 4. Safe Crushing Test Strength

Nominal internal diameter	Pounds per foot of effective length	
	Standard strength	Extra strength
in		
4	1350	1500
6	1350	1500
9	1350	1850
12	1450	2250
Other sizes	to be ascertained by purchaser from supplier	

If the purchaser so requires, pipes at the rate of 10 per 1000 shall be selected at random from every batch of 1000 or less and submitted to this test in his presence. Should no failures occur the batch shall be deemed to comply with these requirements. Should one pipe fail, the same number of specimens shall be selected at random from the same batch and submitted to this test. Should no more failures occur the batch shall be deemed to comply with these requirements. Should more than one pipe fail out of the total number of specimens tested the batch offered shall be deemed not to comply with the requirements of the relevant class.

Ultimate strength. Sufficient ultimate strength tests shall be made by the manufacturer to enable him to maintain the ultimate strength of his pipes and records shall be kept for inspection but such tests need not be carried out on complete pipes. Additional ultimate strength tests may be made at the request and cost of the purchaser.

Absorption Tests

11. One absorption test in accordance with Appendix B shall be made at the manufacturers' works in respect of every 1000 pipes or fittings supplied.

The percentage increase in weight of each test piece by absorption of water shall not exceed the values given in Table 5.

Additional absorption tests may be made at the request and cost of the purchaser.

Table 5. Maximum Permissible Increase in Weight

Thickness of pipe or fitting	Per cent of dry weight
Up to $\frac{3}{4}$ in	6
Over $\frac{3}{4}$ in and up to 1 in	7
Over 1 in and up to $1\frac{1}{4}$ in	8
Over $1\frac{1}{4}$ in and up to $1\frac{1}{2}$ in	9
Over $1\frac{1}{2}$ in	10

Hydraulic Proof Test

12. When subjected to a hydraulic test at the manufacturers' works, straight pipes shall withstand an internal hydraulic pressure on the barrels of 20 lb/sq in and fittings, except channel fittings, shall withstand a pressure of 10 lb/sq in without leakage. The pressure shall be applied at the rate not exceeding 10 lb/sq in in five seconds, and full pressure shall be maintained for at least five seconds. Care should be taken to ensure that all air is expelled before the test is commenced. This test shall be carried out at the request and cost of the purchaser.

Acid and Alkali Resistance Tests

13. When tested in accordance with Appendix C the loss in weight of any specimen after being immersed for 48 hours in a 1.0 normal solution of hydrochloric or nitric or sulphuric or acetic acid or of sodium hydroxide (caustic soda) shall not exceed 0.25 per cent of dry weight. Tests shall be carried out at the request and cost of the purchaser in any or all of the above solutions.

Inspection and Testing

14. The manufacturer on premises agreed by him, and at his own cost except where otherwise stated shall provide the necessary gauges, supply and prepare all test pieces, and supply all labour and apparatus for testing which may be necessary for carrying out the tests and requirements of this standard. If he so decides the purchaser or his representative(s) may be present at the carrying out of tests.

Compliance

15. Should any one of the test pieces taken from the samples first selected, fail to pass any of the additional tests specified in Clauses 11, 12 and 13; then for each such failure two further test samples from the same batch shall be selected at random. Should either of these two further samples fail to pass the particular test, the batch shall be deemed not to comply with this British Standard.

The costs of such additional tests shall be borne:

- a. by the purchaser if results show that the articles comply with this British Standard,
- b. by the manufacturer if the results show that the articles do not comply with this British Standard.

Table showing dead weight of Pipes with Measurements *contd.*

Dia. of Pipes.	No. of Lineal Feet.	Measurement.	Dead Weight.	Total Dead Weight Nested.
18 inch	9 lineal feet	... 40 cubic feet	... 864 lbs.	...
15 inch	11 lineal feet	... 40 cubic feet	... 814 lbs.	...
12 inch	18 lineal feet	... 40 cubic feet	... 819 lbs.	...
10 inch	26 lineal feet	... 40 cubic feet	... 936 lbs.	...
9 inch	29 lineal feet	... 40 cubic feet	... 798 lbs.	...
8 inch	41 lineal feet	... 40 cubic feet	... 938 lbs.	... 938 lbs.
7 inch	54 lineal feet	... 40 cubic feet	... 1040 lbs.	... 1040 lbs.
6 inch	62 lineal feet	... 40 cubic feet	... 908 lbs.	... 908 lbs.
5 inch	88 lineal feet	... 40 cubic feet	... 1034 lbs.	... 1034 lbs.
4 inch	114 lineal feet	... 40 cubic feet	... 1026 lbs.	... 1026 lbs.
3 inch	176 lineal feet	... 40 cubic feet	... 1056 lbs.	... 1056 lbs.
2 inch	220 lineal feet	... 40 cubic feet	... 1760 lbs.	... 1760 lbs.
12 inch	17 lineal feet	} 40 cubic feet	{ 774 lbs.	} 1643 lbs.
9 inch	17 lineal feet		{ 467 lbs.	
6 inch	17 lineal feet		{ 249 lbs.	
4 inch	17 lineal feet		{ 153 lbs.	
10 inch	26 lineal feet	} 40 cubic feet	{ 936 lbs.	} 1550 lbs.
6 inch	26 lineal feet		{ 380 lbs.	
4 inch	26 lineal feet		{ 234 lbs.	
9 inch	26 lineal feet	} 40 cubic feet	{ 715 lbs.	} 1678 lbs.
7 inch	26 lineal feet		{ 501 lbs.	
5 inch	26 lineal feet		{ 306 lbs.	
3 inch	26 lineal feet		{ 156 lbs.	
9 inch	27 lineal feet	} 40 cubic feet	{ 743 lbs.	} 1381 lbs.
6 inch	27 lineal feet		{ 395 lbs.	
4 inch	27 lineal feet		{ 243 lbs.	
9 inch	27 lineal feet	} 40 cubic feet	{ 743 lbs.	} 1222 lbs.
5 inch	27 lineal feet		{ 317 lbs.	
3 inch	27 lineal feet		{ 162 lbs.	
9 inch	28 lineal feet	} 40 cubic feet	{ 770 lbs.	} 1099 lbs
5 inch	28 lineal feet		{ 329 lbs.	

Table showing dead weight of Pipes with Measurements *contd.*

Dia. of Pipes.	No. of Lineal Feet.	Measurement.	Dead Weight.	Total Dead Weight Nested.
4 inch	28 lineal feet	} 40 cubic feet	{ 770 lbs.	} 1022 lbs.
9 inch	28 lineal feet		{ 252 lbs.	
3 inch	28 lineal feet	} 40 cubic feet	{ 770 lbs.	} 938 lbs.
8 inch	28 lineal feet		{ 168 lbs.	
4 inch	37 lineal feet	} 40 cubic feet	{ 846 lbs.	} 1721 lbs.
6 inch	37 lineal feet		{ 542 lbs.	
8 inch	37 lineal feet		{ 333 lbs.	
3 inch	37 lineal feet	} 40 cubic feet	{ 846 lbs.	} 1610 lbs.
6 inch	37 lineal feet		{ 542 lbs.	
8 inch	37 lineal feet		{ 222 lbs.	
3 inch	37 lineal feet	} 40 cubic feet	{ 846 lbs.	} 1503 lbs.
5 inch	37 lineal feet		{ 435 lbs.	
8 inch	37 lineal feet		{ 222 lbs.	
4 inch	41 lineal feet	} 40 cubic feet	{ 938 lbs.	} 1307 lbs.
8 inch	41 lineal feet		{ 369 lbs.	
3 inch	41 lineal feet	} 40 cubic feet	{ 938 lbs.	} 1184 lbs.
7 inch	41 lineal feet		{ 246 lbs.	
3 inch	50 lineal feet	} 40 cubic feet	{ 963 lbs.	} 1850 lbs.
5 inch	50 lineal feet		{ 587 lbs.	
7 inch	50 lineal feet		{ 300 lbs.	
5 inch	51 lineal feet	} 40 cubic feet	{ 982 lbs.	} 1581 lbs.
7 inch	51 lineal feet		{ 599 lbs.	
4 inch	53 lineal feet	} 40 cubic feet	{ 1021 lbs.	} 1498 lbs.
7 inch	53 lineal feet		{ 477 lbs.	
3 inch	53 lineal feet	} 40 cubic feet	{ 1021 lbs.	} 1339 lbs.
7 inch	53 lineal feet		{ 318 lbs.	
4 inch	61 lineal feet	} 40 cubic feet	{ 893 lbs.	} 1442 lbs.
6 inch	61 lineal feet		{ 549 lbs.	
3 inch	61 lineal feet	} 40 cubic feet	{ 893 lbs.	} 1259 lbs.
6 inch	61 lineal feet		{ 366 lbs.	
3 inch	87 lineal feet	} 40 cubic feet	{ 1022 lbs.	} 1544 lbs.
5 inch	87 lineal feet		{ 522 lbs.	

The above table gives the approximate number and also the dead weight of each size of Pipe that can be packed into 40 cubic feet (1 Ton measurement).

PACKING.—An allowance is made in the above calculation for a minimum amount of straw for packing. If extra is used, the measurements should be reduced accordingly

It will be appreciated by all concerned that there may be instances where a particular consignment might result in loss of room in the ship's hold, but such waste room can always be utilised for small items such as Gullies, Bends, etc., if a proportion of these can be ordered with each consignment, thereby transshipping these free of cost.



Glazed Stoneware Tested Pipes

These pipes are carefully selected, and each pipe is subjected to considerable internal hydraulic pressure.



As already explained on page 15, the testing of Stoneware pipes under pressure reveals the slightest flaw. Every tested pipe supplied is stencilled to indicate that it has satisfactorily stood the test.

Tested pipes of Stoneware Ltd., Midland Stoneware are supplied and stencilled thus:



Special Joints can be supplied on tested pipes to instructions.

Quotations on application.

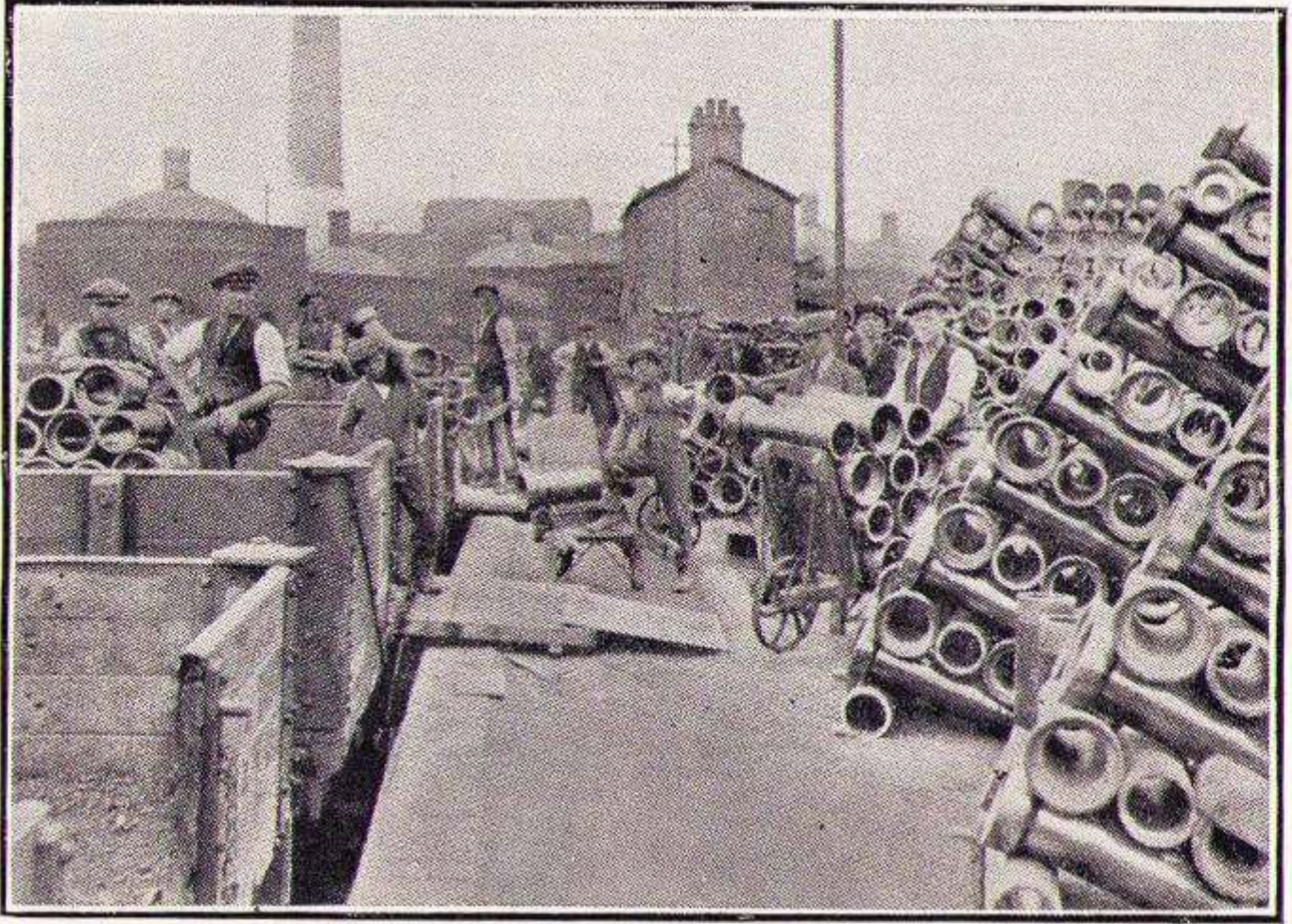

● *Loading for Rail Transport*



STONEWARE LIMITED

SALT-GLAZED SANITARY PIPES AND FITTINGS

"HAND" OF CHANNEL GOODS, ETC.

In order to prevent confusion the Trade has decided that "Handed" Articles shall be judged by looking **from the Spigot end towards the Socket**. Thus if you place an article on the ground with the Spigot end nearest and the Socket end furthest from you the hand will be easily determined. In the case of Gullies and Traps with side inlets, the outlet should be placed nearest you and the back furthest away. Below are a number of illustrations for guidance.

CHANNEL BENDS OR CURVES

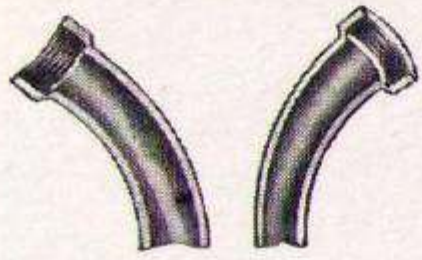

Left Right

INSPECTION BENDS

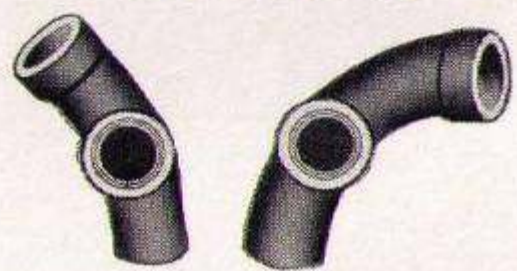

Left Right

GULLIES

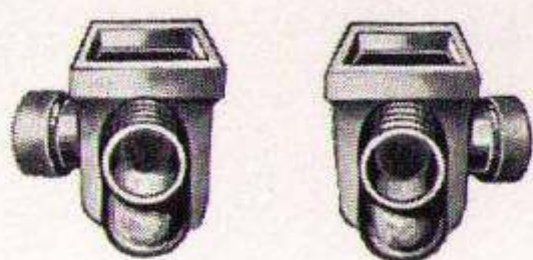

Left Right

CHANNEL JUNCTIONS

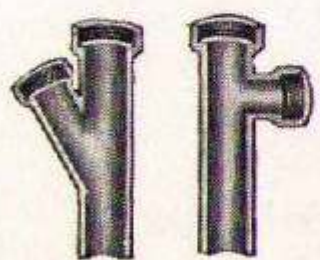

Left Right

ACCESS BENDS



Left Right

INSPECTION JUNCTIONS

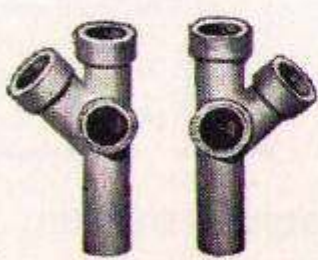

Left Right

ACCESS JUNCTIONS

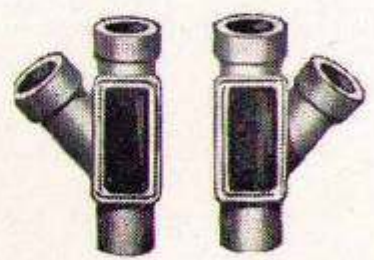

Left Right



WEIGHTS OF PIPES

Size	2"	3"	4"	5"	6"	7"	8"	9"	10"	12"	15"	18"
	210	125	87	71	51	45	34	28	23	16	10	8 yards to 1 ton

2 in, 3 in, 4 in, 5 in, 6 in, 7 in, 8 in, 9 in, 10 in, 12 in, 15 in, 18 in.
 Pipes 2 in. to 6 in. diam. supplied in 2 ft. and 3 ft. lengths.
 Pipes 9 in. to 18 in. diam. supplied in 3 ft. lengths.

Other lengths supplied to order.

SHORT LENGTHS OF PIPES are supplied also in lengths of 6 in, 9 in. and 12 in. to avoid the necessity of cutting for house drains, etc.

Short Lengths are charged as 2 feet.

PERFORATED PIPES are supplied to order.

BUTT PIPES without Sockets are supplied as required

Quotations on application.



BENDS

No. 1102



12° 30 to the circle

No. 1105



45° 8 to the circle

No. 1108



Chubb Bend

No. 1103



15° 24 to the circle

No. 1106



60° 6 to the circle

No. 1109



Knuckle Bend

No. 1104



30° 12 to the circle

No. 1107



1/4 Bend 4 to the circle

No. 1110

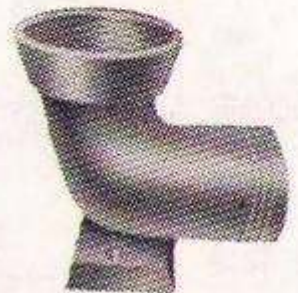

Rest Bend



JUNCTIONS

SINGLE JUNCTIONS

No. 1111

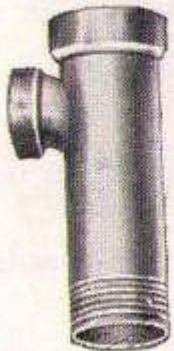

No. 1112



No. 1113



No. 1114



Junctions with 2" to 6" Diameter main are usually supplied in 2' lengths
7" to 12" Diameter in 2' 6" lengths.
Larger Diameters in 2', 2' 6" or 3' lengths.

DOUBLE JUNCTIONS

No. 1115



No. 1116



No. 1117



No. 1118

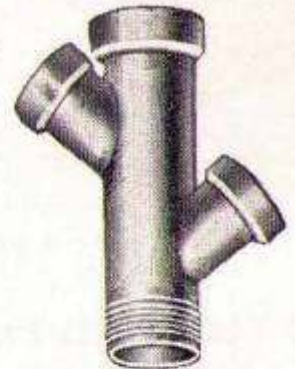

No. 1119



No. 1120



Short Junctions are charged at the same price as Junctions 2' long



STONEWARE LIMITED

No. 1121

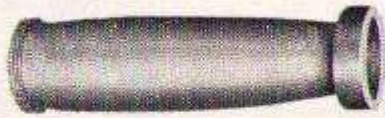

TAPER PIPE

No. 1122



PERFORATED PIPE

Supplied perforated over the whole or part of the surface.

No. 1123



OBLIQUE SADDLE
JUNCTION PIECE

No. 1124



SQUARE SADDLE
JUNCTION PIECE

For connecting Branch Drains with existing sewers

STOPPERS FOR JUNCTIONS
No 1125



Ordinary

No 1126



Stanford Jointed

No 1127



Loose Collar

No 1128



Double Socket

(Also stocked in larger sizes)



Access Pipes, Junctions and Bends

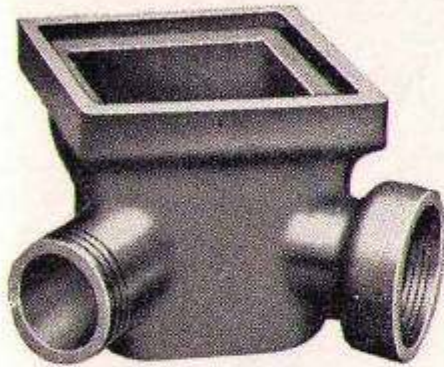

No 1129

The access opening permits of the insertion of a testing plug.

Armstrong Inspection Bend

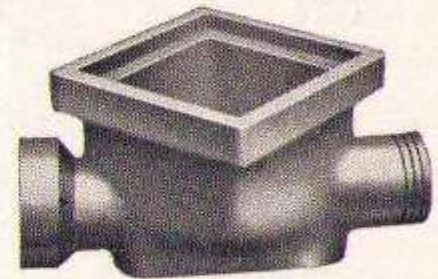

No 1130

Armstrong Inspection Pipe

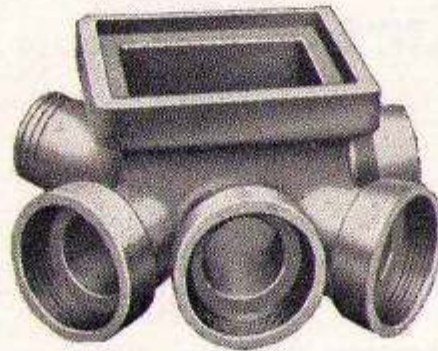

No. 1131

Armstrong Inspection Junction

No 1132

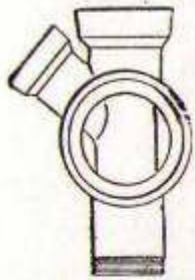

Single Oblique left hand

No 1136

NO 1133

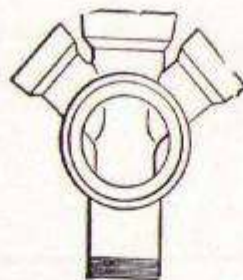

JUNCTIONS.

Double Oblique.

No 1137

No 1134

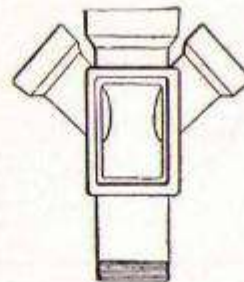

No 1138

No 1135

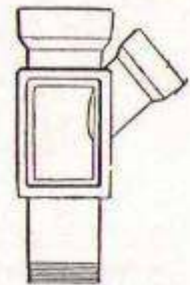

Single Oblique—right hand

No 1139

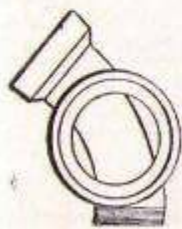

BEND—left hand.

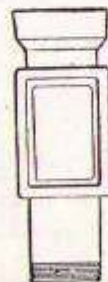

PIPES.

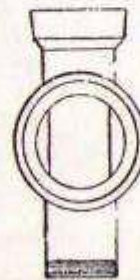

BEND—right hand.

Stoneware covers are supplied unless otherwise ordered.
Bends are supplied one-quarter, one-eighth or one-sixteenth circle.



STONEWARE PIPE BENDS, 4"

Nº1

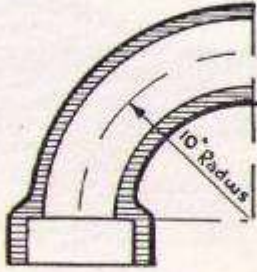

Nº2 $\frac{1}{4}$ CIRCLE

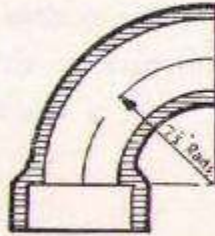

Nº3

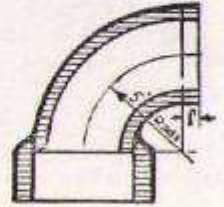

Nº4

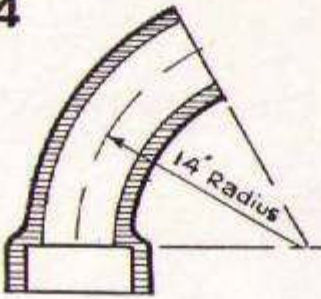

Nº5 $\frac{1}{6}$ TH CIRCLE

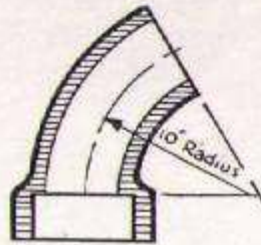

Nº6

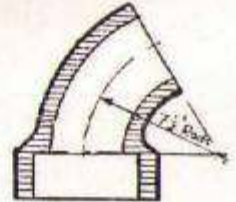

Nº7

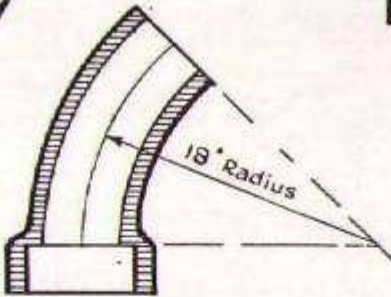

Nº8 $\frac{1}{8}$ TH CIRCLE

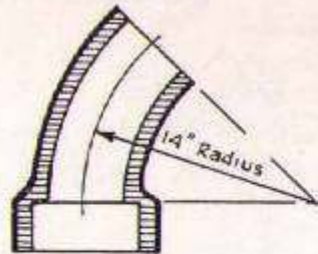

Nº9

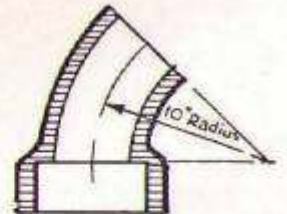

Nº10 $\frac{1}{12}$ TH CIRCLE

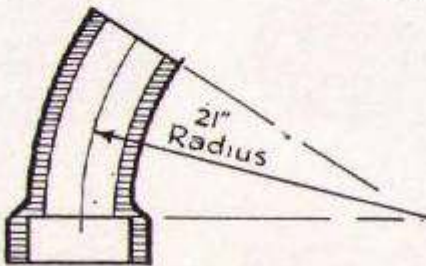

Nº11 $\frac{1}{16}$ TH CIRCLE

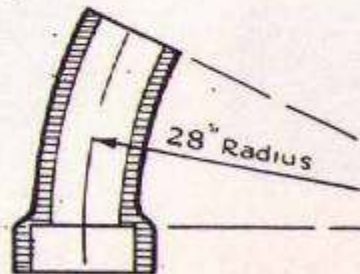

Nº12 $\frac{1}{32}$ ND CIRCLE

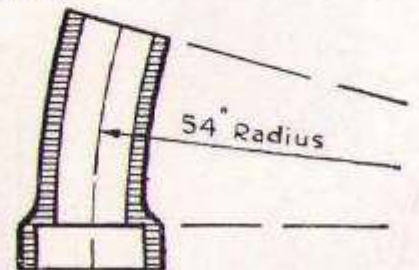

All other details as British Standard Specification No. 65 for Salt Glazed Ware Pipes



STONEWARE PIPE BENDS, 6"

$\frac{1}{4}$ CIRCLE

Nº1

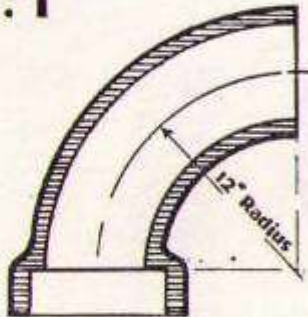

Nº2

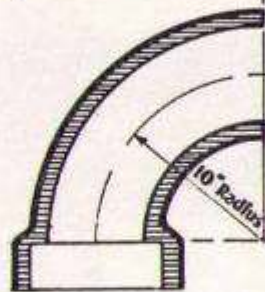

Nº3

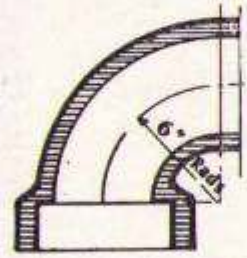

$\frac{1}{6}$ CIRCLE

Nº4

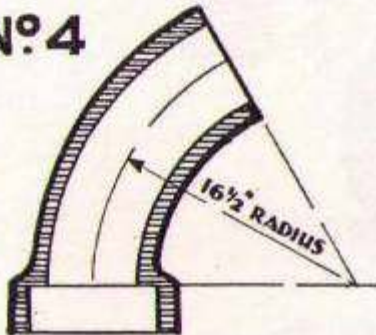

Nº5

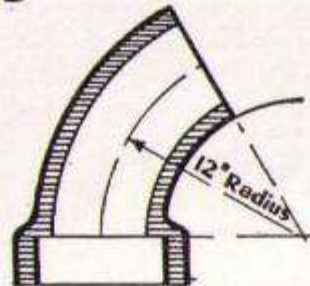

Nº6

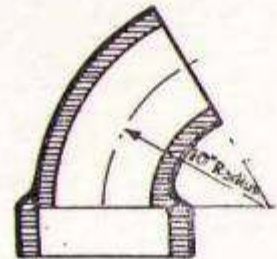

$\frac{1}{8}$ CIRCLE

Nº7

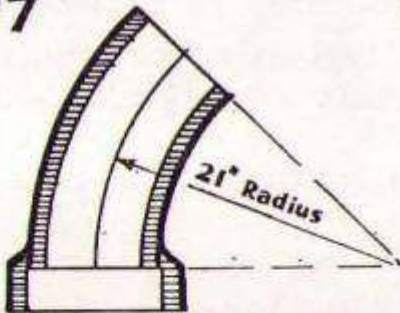

Nº8

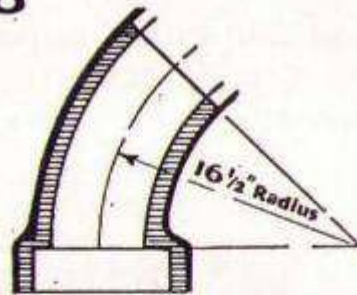

Nº9

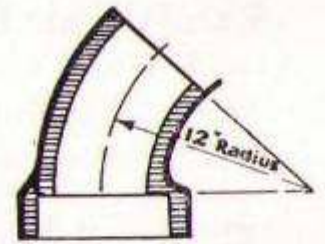

Nº10

$\frac{1}{12}$ CIRCLE

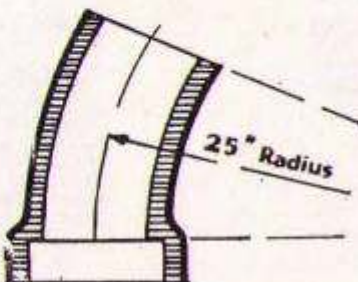

Nº11

$\frac{1}{16}$ CIRCLE

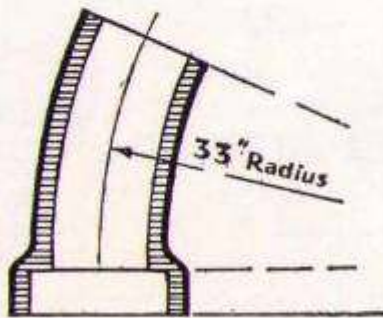

Nº12

$\frac{1}{32}$ CIRCLE

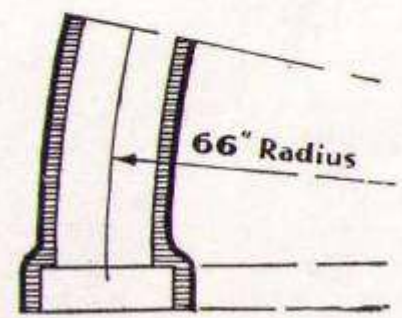

All other details as British Standard Specification No. 65 for Salt Glazed Ware Pipes



STONEWARE LIMITED

Tumbling Bay Junctions No 1140

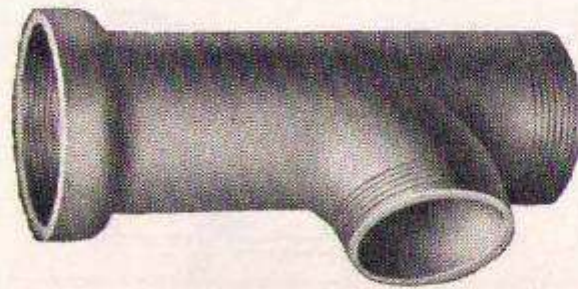

No 1141

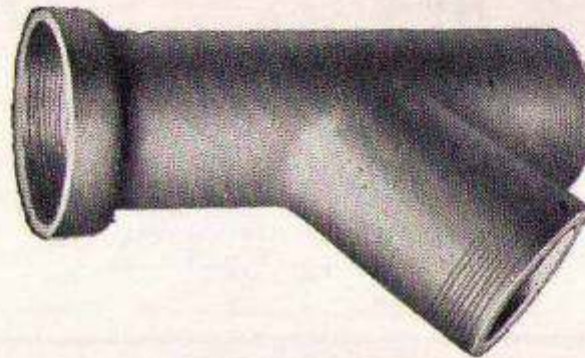

Weight Calculator for Burned Clay. (Red, Blue or Salt-Glazed)

The rule is to find, first the cubic capacity, multiply the result by 5 and divide by 72 (omitting fractions). A brick $9 \times 4\frac{1}{2} \times 3$ would thus work out as follows:—

$ \begin{array}{r} 9 \times 4\frac{1}{2} \times 3 \\ \hline 4\frac{1}{2} \\ \hline 40 \\ 3 \\ \hline 120 \\ 5 \quad \text{or} \\ \hline 72)600(8\frac{1}{3} \text{ lbs.} \\ \underline{576} \\ 24 \\ \hline \therefore 8\frac{1}{3} \text{ lbs.} \end{array} $	$ \begin{array}{r} 12 \times 6 \times 6 \\ \hline 6 \\ \hline 72 \\ 6 \\ \hline 432 \\ 5 \\ \hline 72)2160(30 \text{ lbs.} \\ \underline{216} \\ \dots \\ \hline \therefore 30 \text{ lbs.} \end{array} $	<p style="text-align: right;">or to ascertain number to ton</p> $ \begin{array}{r} \text{lbs.} \\ 30)2240(74 \text{ (approx.) to ton.} \\ \underline{210} \\ 140 \\ \underline{120} \\ \dots \\ \hline \therefore \text{approximately } 74 \text{ to ton} \end{array} $
--	---	--



TAPERS

ORDINARY TAPERS

No 1142



No 1143



No 1144



SHORT TAPERS

No 1145



No 1146



CONNECTORS

No 1147



No 1148



No 1149





Junction-Caps for closing Socket of Junction Branches

JOINDER on JUNCTION BRANCH

Fig 1150



Sectional
Elevation
of same

This Joinder is made in one piece with the Socket of the Junction Branch. A cut at AA as shewn in the illustration, is made during manufacture, but leaving sufficient thickness to preserve strength. The outer disc can be easily removed by a chisel, leaving the interior of the socket clean and ready for making a connection.

No. 1150a—This Joinder is similar to above, but a loose stoneware cap is fitted over the socket and secured in position with a bitumen or cement joint.

These two types of Junction-Caps can be made to various sizes of sockets.



CHANNELS
in
Salt-Glazed Stoneware

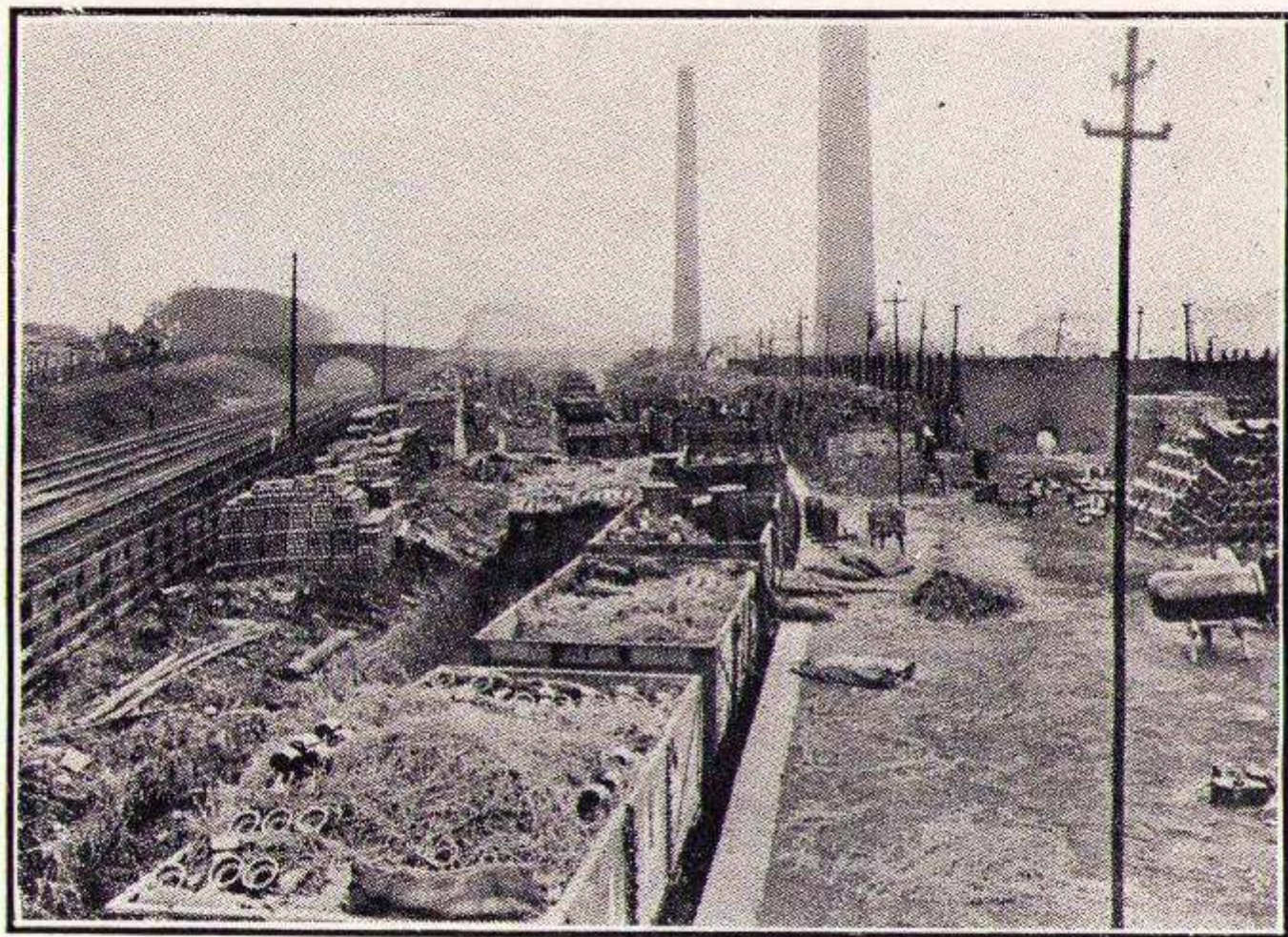

'B' Loading Deck



CHANNEL SECTIONS IN SALT-GLAZED STONEWARE
HALF-SECTION CHANNEL JUNCTIONS

Fig. 1200



Fig. 1201



Fig. 1202



Fig. 1203



Fig. 1204



Fig. 1205



Fig. 1206



Fig. 1207

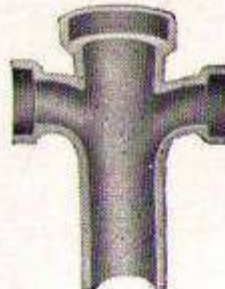

Fig. 1208



SHORT LENGTHS

Fig. 1209



Fig. 1210



Fig. 1211



Fig. 1212



Fig. 1213



Fig. 1214



Fig. 1215



Fig. 1216



Fig. 1217





STONEWARE LIMITED

Half or Three-Quarter Channel Bends.

Channel Sections in Salt-Glazed Stoneware

“The reference letters shown against these items are from the H M O W List and are reprinted for reference as many lists are still in use.

These reference letters have been replaced by the Ministry of Works list—see page 62.”

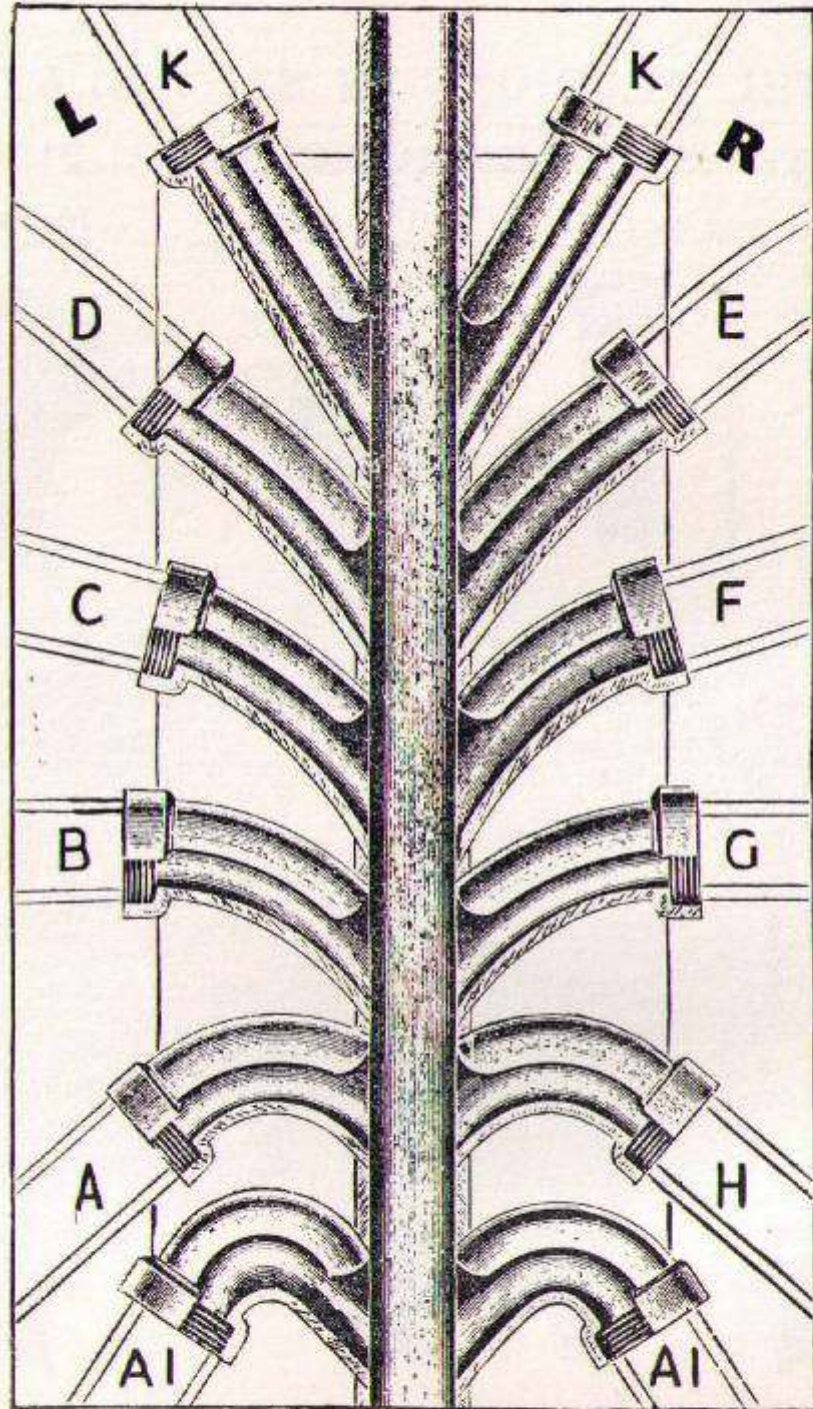

No 1218

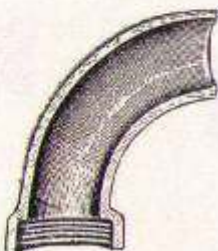

No 1219



No 1220



For further details of Channel Bends see page 62



Channel Section Bends and Bends with
Inlets in Salt-Glazed Stoneware.

**Half-Section Channel Bends or
Three-Quarter Section Channel Bends.**

(Barron Bends or Curl-over Bends)

Can be supplied with—

**Ordinary Ends,
Splayed Ends,
Splayed and Seated Ends,**
To form any desired Angle, left or right.

No 1221



Illustration of
Ordinary End

No 1222



Illustration of
Splayed End

No 1223

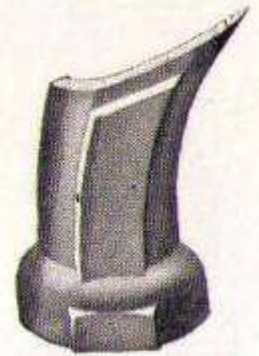

Illustration of
Splayed and Seated Ends

INSPECTION BENDS

ACCESS BENDS

No 1224

No 1225

No 1226

No 1227

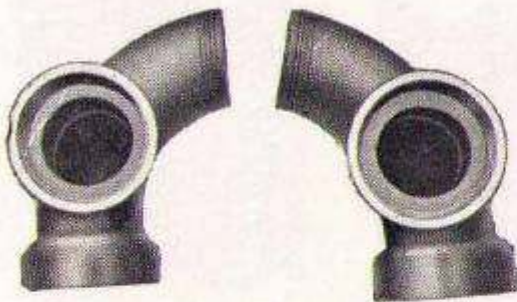

One-Quarter Circle (90°)



One-Eighth Circle (45°)





STONEWARE LIMITED

SHEFFIELD CHANNEL BLOCKS



No. 1
 4 inches by 6 inches
 4 " 12 "
 4 " 18 "
 6 " 6 "
 6 " 12 "
 6 " 18 "



No. 2
 Taper
 6 inches long
 12 " "
 18 " "

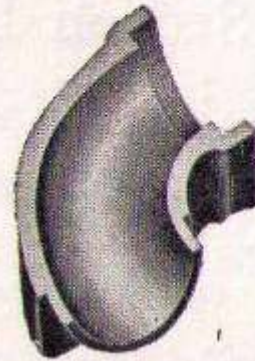

No. 3
 4 inches
 6 "

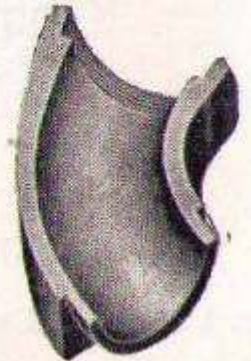

No. 4
 4 inches
 6 "



No. 5
 4 inches
 6 "



No. 6
 4 inches
 6 "

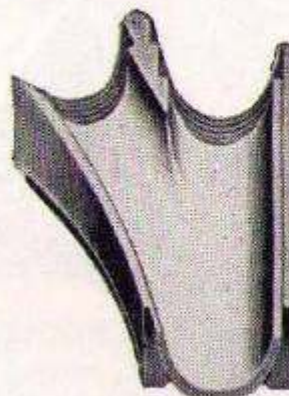

No. 7
 4 ins. by 4 ins.
 4 " 6 "
 6 " 6 "

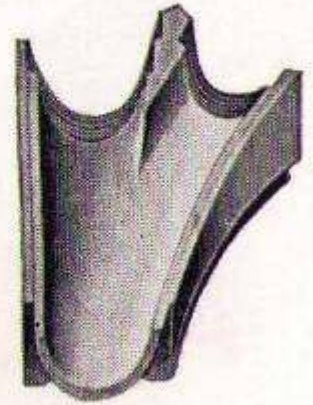

No. 8
 4 ins. by 4 ins.
 4 " 6 "
 6 " 6 "

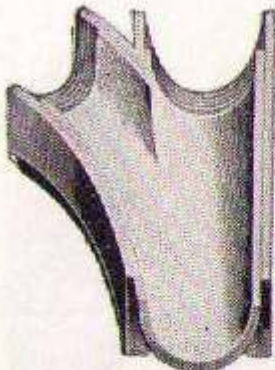

No. 9
 4 inches by 4 inches
 4 " 6 "
 6 " 6 "

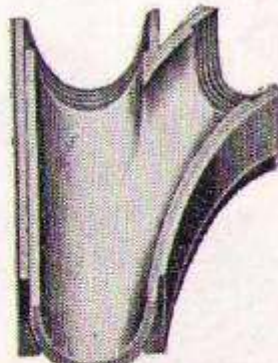

No. 10
 4 inches by 4 inches
 4 " 6 "
 6 " 6 "



No. 11
 4 inches by 4 inches
 4 " 6 "
 6 " 6 "

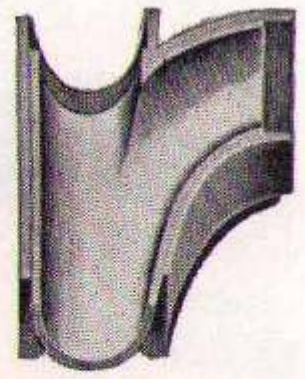

No. 12
 4 inches by 4 inches
 4 " 6 "
 6 " 6 "



SHEFFIELD CHANNEL BLOCKS—*continued*

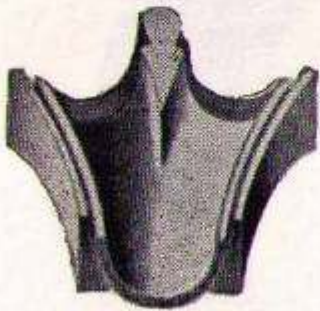

No. 13

4 ins. by 4 ins. by 4 ins.
 4 " 4 " 6 "
 6 " 6 " 6 "

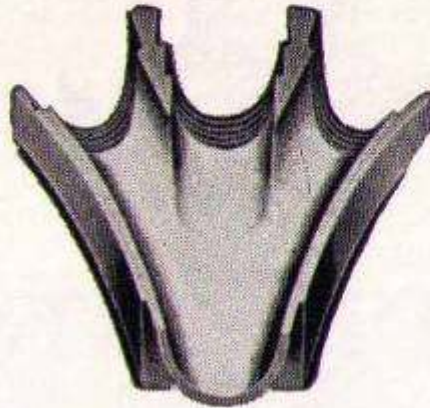

No. 14

4 ins. by 4 ins. by 4 ins.
 4 " 4 " 6 "
 6 " 6 " 6 "



No. 15

4 ins. by 4 ins. by 4 ins.
 4 " 4 " 6 "
 6 " 6 " 6 "

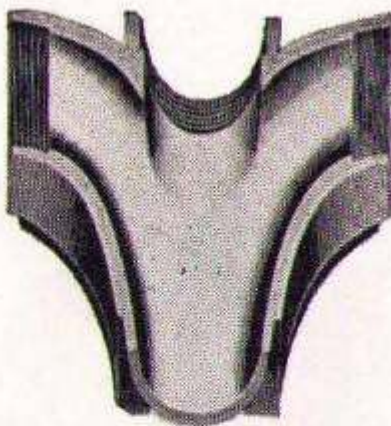

No. 16

4 ins. by 4 ins. by 4 ins.
 4 " 4 " 6 "
 6 " 6 " 6 "



No. 17

TAPER.
 4 in. to 6 in.



No. 18

4 ins. by 4 ins. by 6 ins.



SHEFFIELD CHANNEL BLOCKS—*continued*



No. 19

4 ins by 6 ins

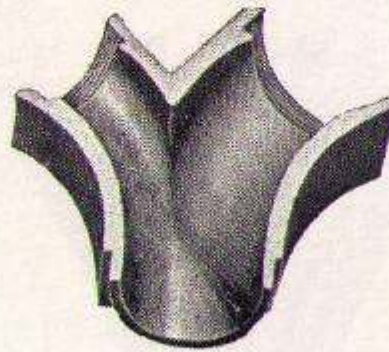

No. 20

4 ins by 6 ins



No. 21

TAPER

4 ins to 6 in

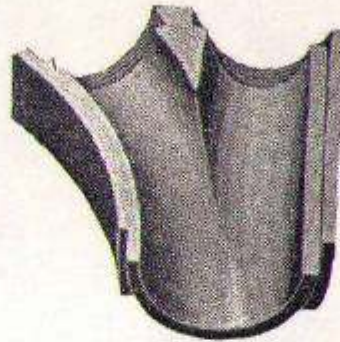

No. 23

4" by 4" by 6"



No. 22

4 ins by 4 ins by 6 ins

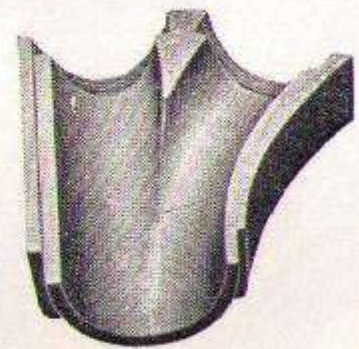

No. 24

4 ins by 4 ins by 6 ins



INTERCEPTORS
GULLIES

ETC.



STONEWARE LIMITED

INTERCEPTORS

No 1250
BRIGHTON INTERCEPTOR

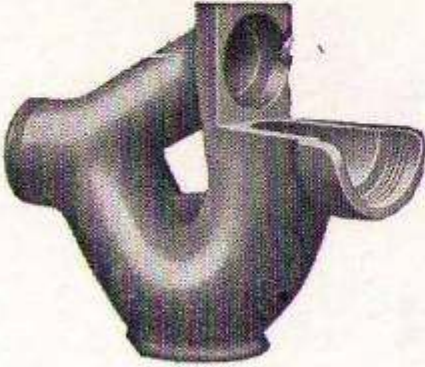

4", 6", 9" and 12" diameter
Also supplied in 4" to 6"
Larger diameters to order.

Unless otherwise ordered, these Interceptors
are supplied with Stanford Stoppers.

One of the most popular patterns
of Intercepting Traps for discon-
necting House Drains from Main
Sewers.

4", 6", 9" and 12" diameter.

No 1252



4", 6", 9" and 12"
Diameter.

No 1251
SQUARE-END INTERCEPTOR



No 1253
DEEP SEAL INTERCEPTOR





Glazed Stoneware Sewer-Gas Interceptors

No 1254
CROYDON TRAP



No 1255
KENON

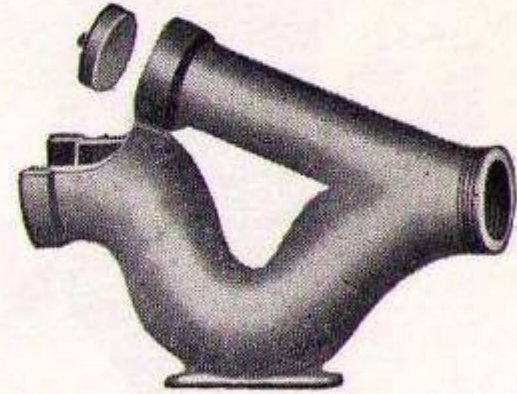

Unless otherwise ordered, these Traps are supplied with Stanford Stoppers, but they can also be supplied with Stanford Screw Stoppers, Lever Locking Stoppers or galvanised sealing plates.

No 1256 WINSER



No 1257
WEAVER TRAP



No 1258
BUCHAN TRAP





STONEWARE LIMITED

Glazed Stoneware Sewer-Gas Interceptors *cont.* & Syphon Traps

No 1259
Lever Stopper only supplied to order



No 1260
D.A.D. TRAP (Dublin Artisan Dwelling)



No 1261
REVERSE ACTION INTERCEPTOR

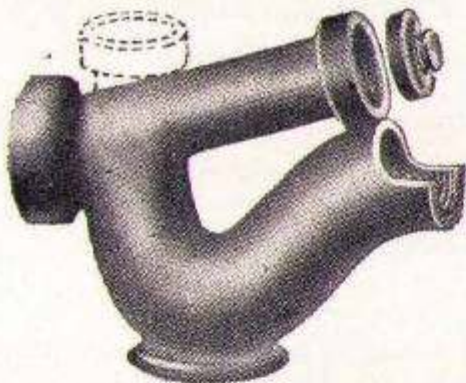

No 1262
WHOLE-END INTERCEPTOR

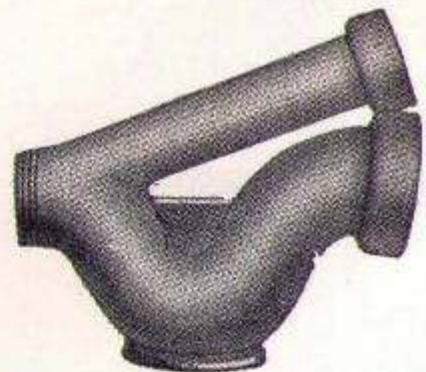

No 1263 P TRAP

No 1264 SYPHON

No 1265 S TRAP

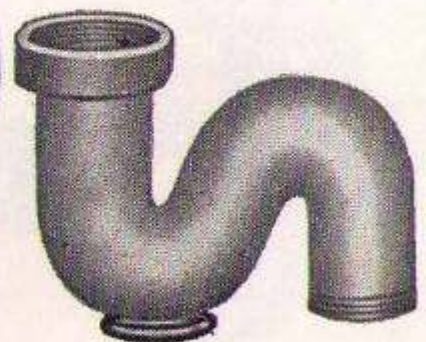

P Trap, 2", 3", 4" & 6" diam.

4", 6", 9" & 12" diam.

S Trap, 2", 3", 4" & 6" diam.

Larger sizes made to order

Additional inlets if required



YARD GULLIES WITH INLETS



No 1266
INSPECTION
GULLY

No 1267

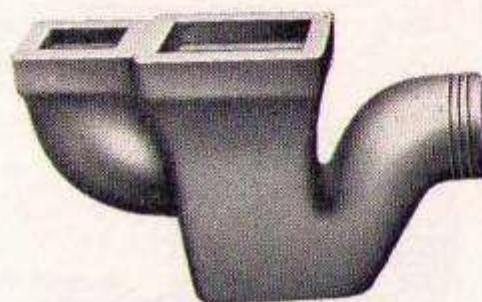

No 1268
Left Rain-water Inlets

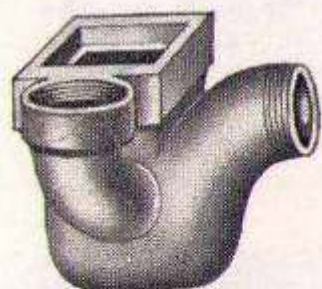

No 1269
Back & Left Rain-water Inlets



No 1270
Back & Right Rain-water Inlets



No 1271



Three Rain-water Inlets

ANGLE-ARM GULLIES

No 1272

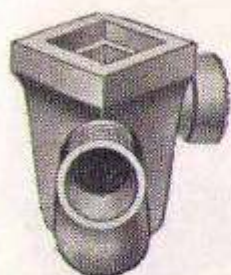

Right Inlet

No 1273



Two Inlets

ANGLE-ARM GULLIES

No 1274



Left Rain-water Inlet

No 1275

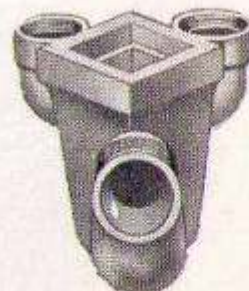

2 Rain-water Inlets



Reversible Gullies in Salt-Glazed Stoneware

No 1277



No 1278



With
Inspection
Eye, Sealing
Plate and
Frame

No 1279



No 1280



No 1281



No 1282



No 1283

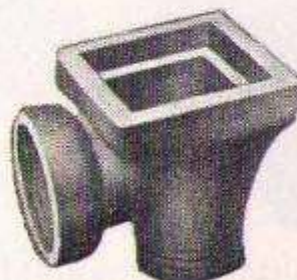

No 1284





Reversible Gullies in Salt-Glazed Stoneware

No 1285



No 1286



Traps may also
have Q or S
Outlets

No 1287



No 1288



These Hoppers are supplied in
6" and 9" diameter, 9" high, Outlet 4" diameter

No 1289



No 1290



No 1291





STONEWARE LIMITED

Inspection and Yard Gullies in Salt-Glazed Stoneware *cont.*

These gullies are provided with inspection eye to facilitate inspection and clearing of drain

No 1292

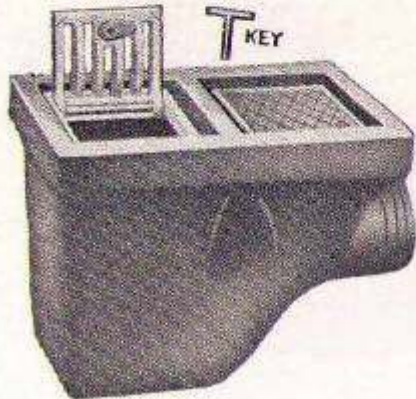

With Galvanised Iron Sealing-Plate and Frame to Inspection Eye

Ordinary loose grating supplied if preferred

No 1293



GULLY, with Rodding Eye



No 1294

Small Size : Grating 6" x 6"
Outlet 4" diam.

Large Size : Grating 9" x 9"
Outlet 4" diam.

Illustrations of Gully Inlets and Sealing Plate and Frame appear on later pages

No 1295

Ordinary No 1296

No 1297

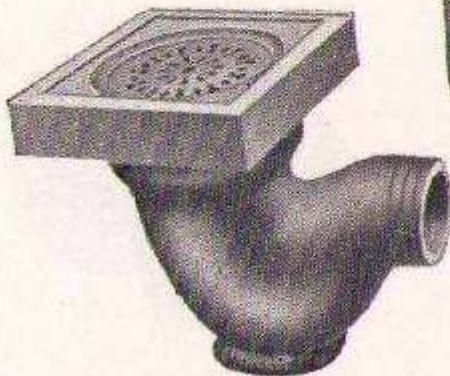

These Gullies have Inspection Eyes fitted with air-tight Stanford Stoppers

Q or S Outlets also supplied



STONEWARE LIMITED



Reversible Gullies and Traps, Rain-water Shoes and Raising Pieces in Salt-Glazed Stoneware

No. 1338 Traps are also supplied with S outlet

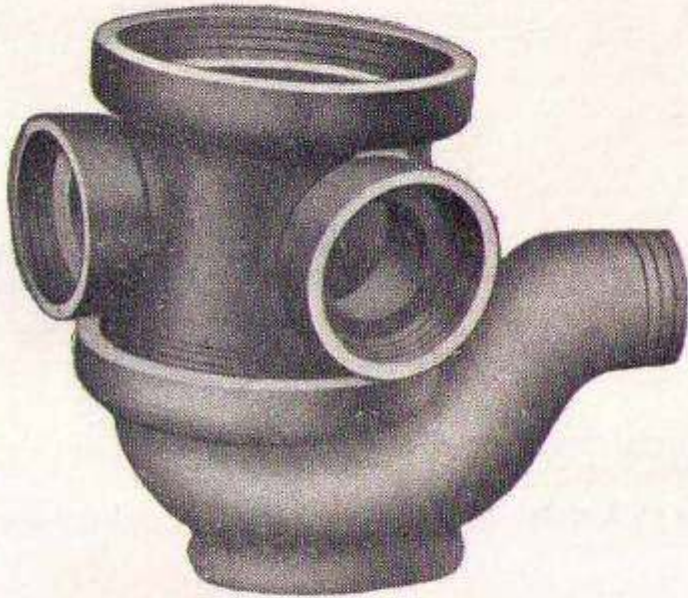

No 1339



No 1340



4", 6", 9" and 12" diameter
6", 9" and 12" high

No 1341



No 1342

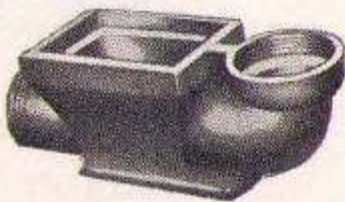

No 1343

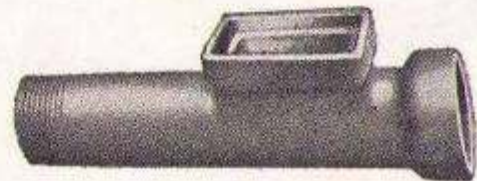

No 1344



No 1345



For further details and Sections of Rain-water Shoes see page 62



STONEWARE LIMITED

Yard Gullies (continued), and Sink Bends in Salt-Glazed Stoneware

No 1306

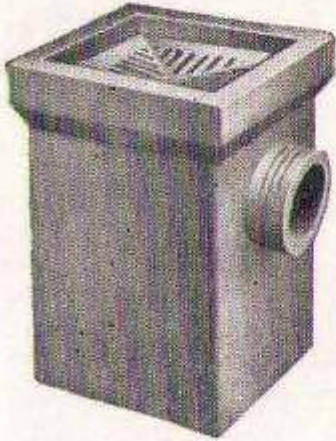

No 1307

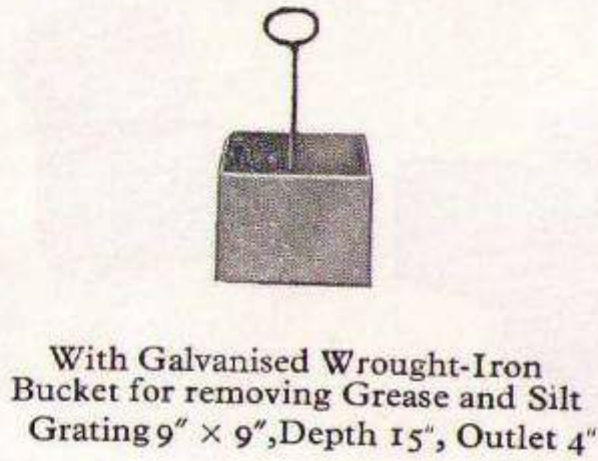
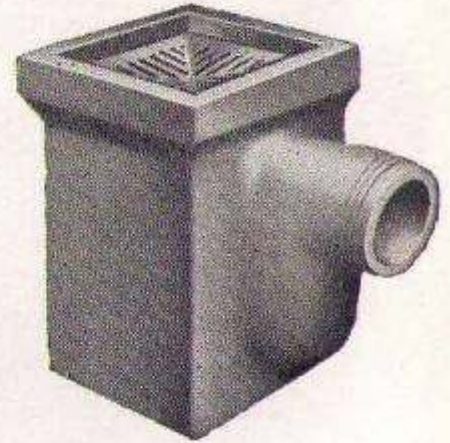

With Galvanised Wrought-Iron Bucket for removing Grease and Silt Grating 9" x 9", Depth 15", Outlet 4"

No 1308



Sink Bends

Made for 9" and 14" Walls

No 1310

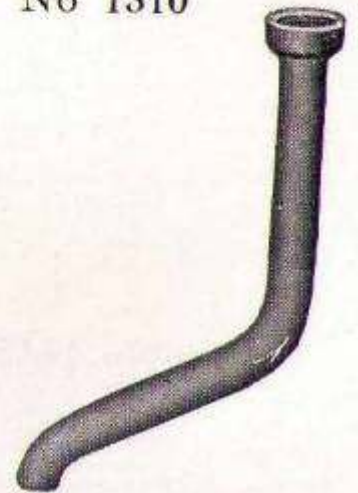

No 1309
2" and 3" diam.

Plain, in one piece

Snouted, in one piece
No 1313

No 1311

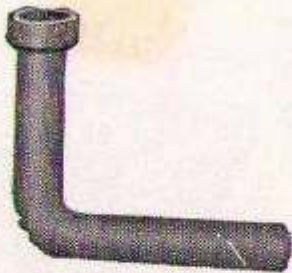

No 1312



Straight Pipes in 15", 18" and 24"



Gully Raising Pieces, Anti-Flood Gully, Interceptor, etc.

No. 1315 Anti-Flood Gully



(See Section of this on page 51)

No 1316 Anti-Flood Interceptor



(See Section of this on page 50)

DRAIN CHUTES

No 1317



No 131



**SEALING PLATE AND FRAME
in Galvanised Iron for
Grease Seal**

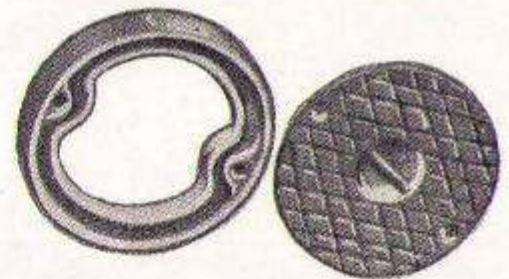

For Sockets of 3" 4" and 6" pipes

RAISING PIECES

No 1319



No 1320



No 1321





STONEWARE LIMITED

DEAN'S PATTERN BALL-VALVE INTERCEPTOR

Copyright Design Registered No. 812248

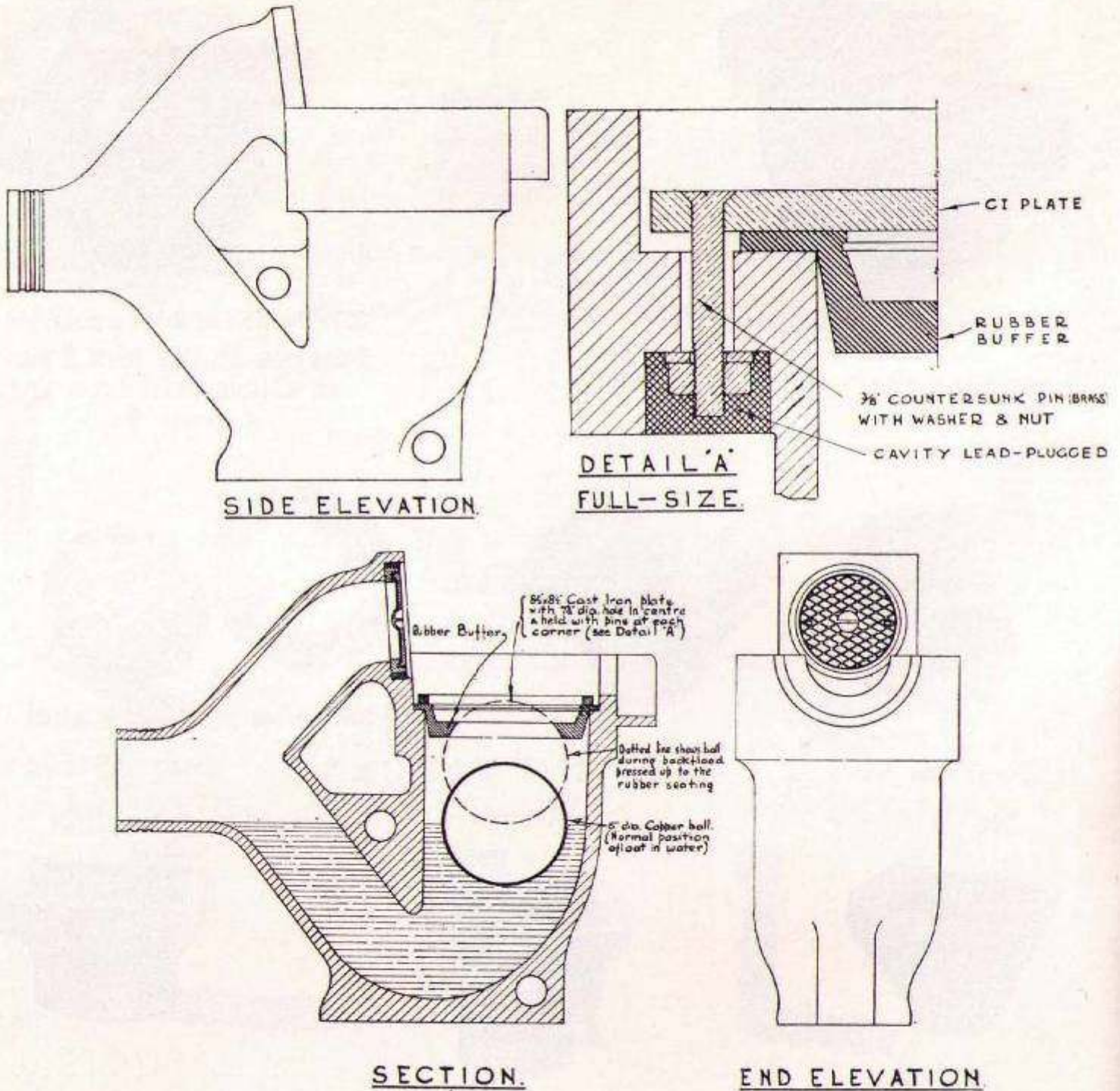



DEAN'S PATTERN BALL-VALVE GULLY

Copyright Design Registered No. 812247

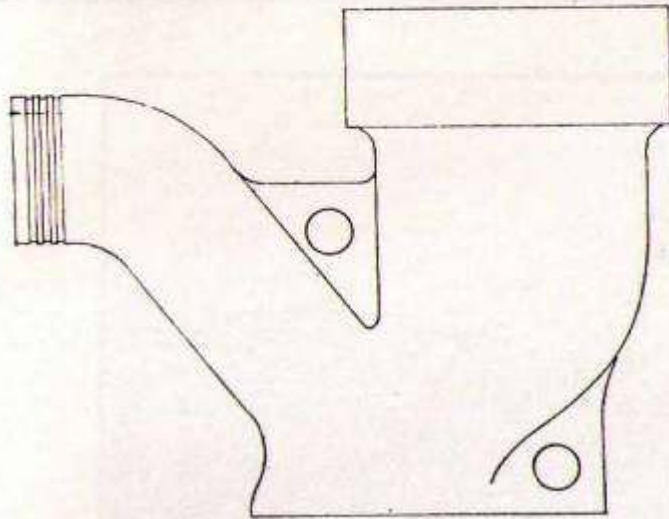

SIDE ELEVATION

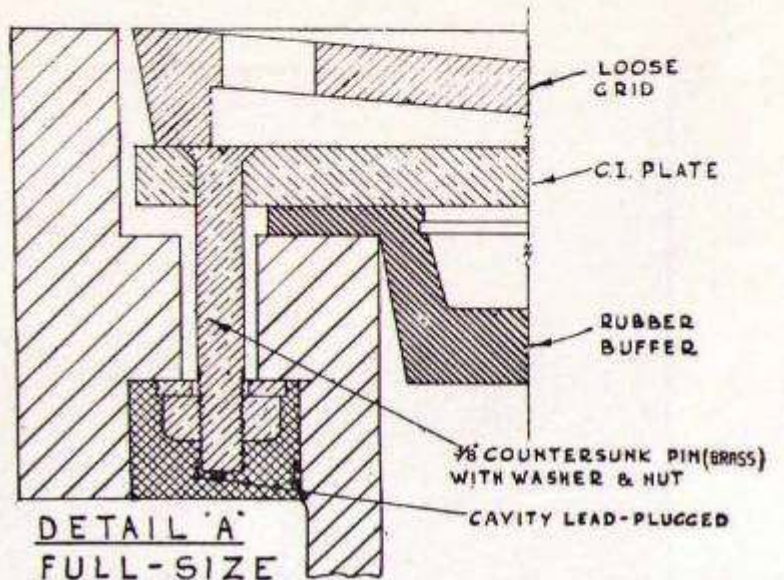

DETAIL 'A'
FULL-SIZE

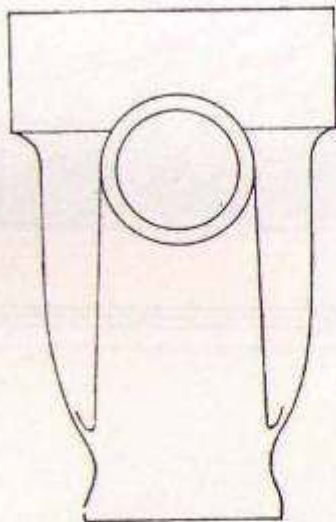

END ELEVATION

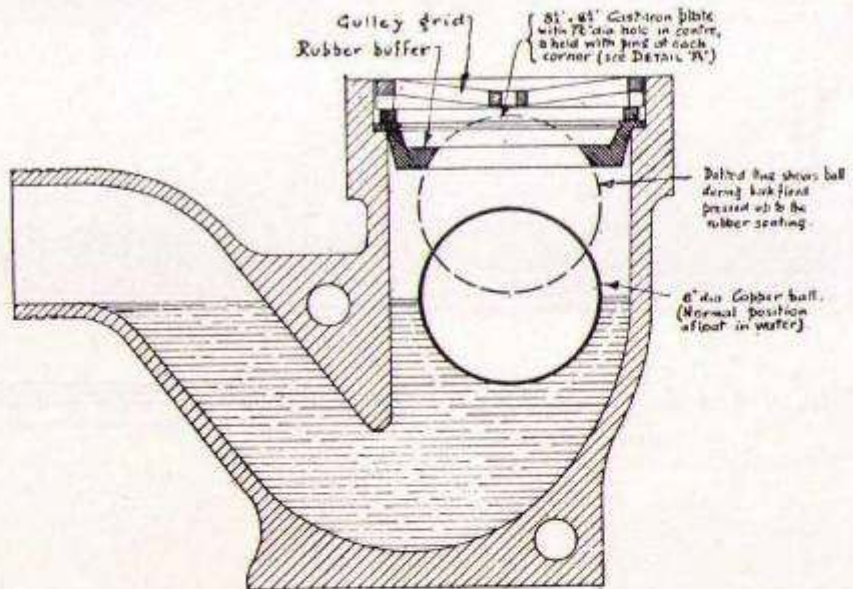

SECTION



*One of the Loading Decks
for Transport*



YARD GULLIES
GREASE TRAPS
ETC.



STONEWARE LIMITED

YARD GULLIES

No 1350

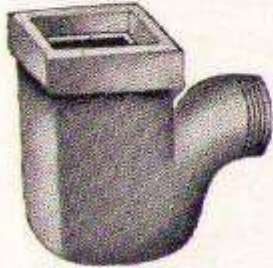

P Arm

No 1351

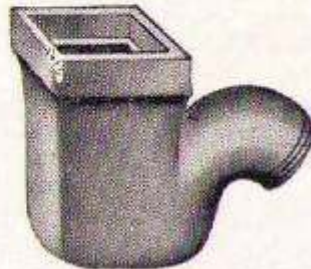

Q Arm

No 1352

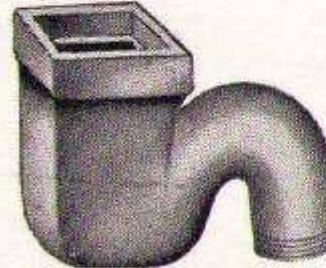

S Arm

No 1353



Angle Arm Gully

Any of the above GULLIES can be supplied WITH INLETS as follows:-

No 1354

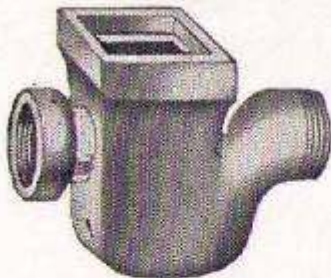

Back Inlet

No 1355

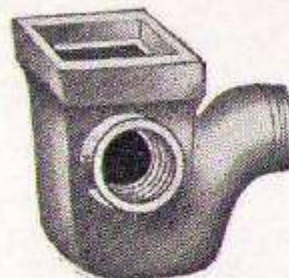

Left Inlet

No 1356

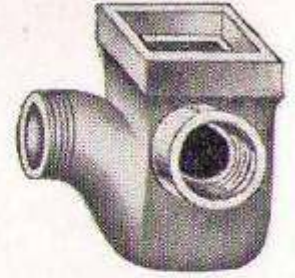

Right Inlet

No 1357

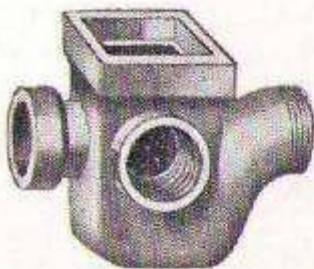

Back & Left Inlets

No 1358

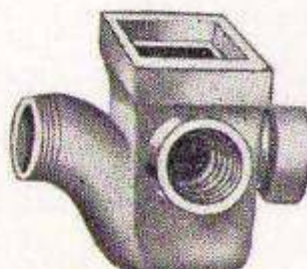

Back & Right Inlets

No 1359

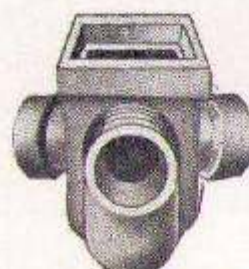

Two Side Inlets

No 1360



Three Inlets

No 1361

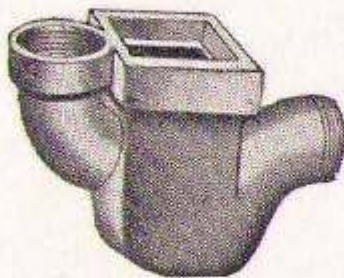

Back Rain-water Inlet

No 1362

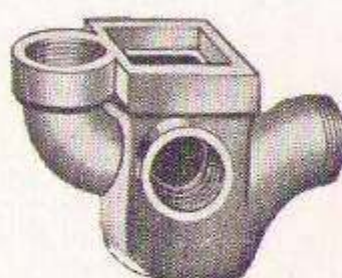

Back Rain-water Inlet
Left Side Inlet

No 1363

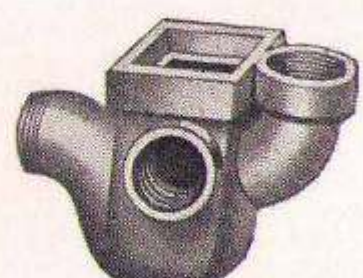

Back Rain-water Inlet
Right Side Inlet



Waste-receivers for Disconnecting Rainwater and Waste Pipes and Intercepting Gullies in Salt-Glazed Stoneware

No 1364

This receiver is designed for the disconnection of waste pipes which therefore prevents the entrance of foul air.

The cast-iron grating intercepts leaves and the outlet grating stops solids.



DEAN'S grease & mud intercepting traps can be supplied in connection with the waste receivers.

S, P or Q Traps are also supplied.

No 1365

Rust Interceptor



Supplied with Grating or Sealing-plate

No 1366

Improved Rain-water Trap



No 1367



No 1368





Dean's Grease and Mud Interceptors in Salt-Glazed Stoneware

No 1369



With galvanised Wrought-Iron
Bucket for removing Grease
and Silt.

Supplied in 6", 9" and 12"

No 1370
Garage Gully



Complete with Galvanised
Perforated Bucket

Supplied in 9" and 12"

With Galvanised Wrought-Iron
Bucket for removing Grease and
Silt.

No 1371

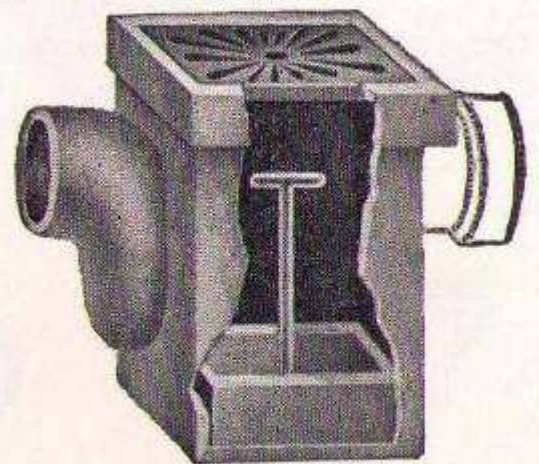

STONEWARE LIMITED



CLOCKFACE
No 1372



18" × 12" × 3" 24" × 12" × 3"
18" × 12" × 4" 24" × 12" × 4"
18" × 12" × 5" 24" × 12" × 5"
18" × 12" × 6" 24" × 12" × 6"

LANE'S PATENT DISH
No 1373



THE
ANTI-SPLASH DISH
No 1374

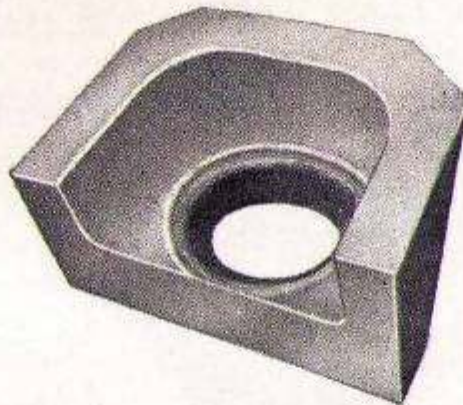

RUST POCKET
No 1375

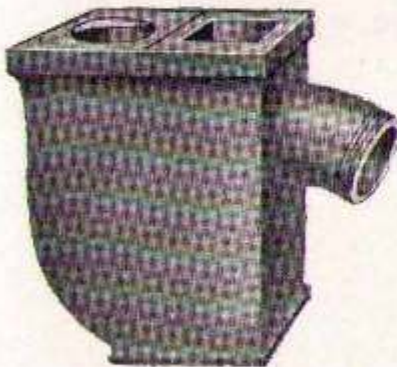

MOSS SIDE PASSAGE GULLY

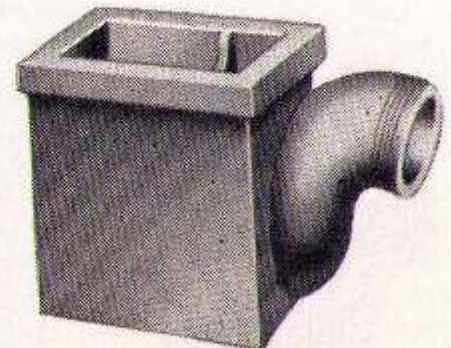

No 1376



STONEWARE LIMITED

GULLIES, ETC., IN SALT-GLAZED STONEWARE

NORTH EASTERN SOCKETED
No 1377



HANDHOLE TRAP
No 1378



IMPROVED TIMES TRAP No 1379



LIVERPOOL D GULLY
No 1380



LIVERPOOL D GULLY
No 1381

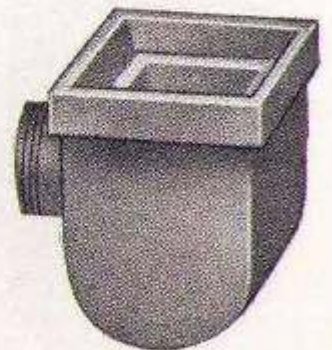



NEW PATTERN "DEAN'S GREASE TRAP"

Patent No. 358339

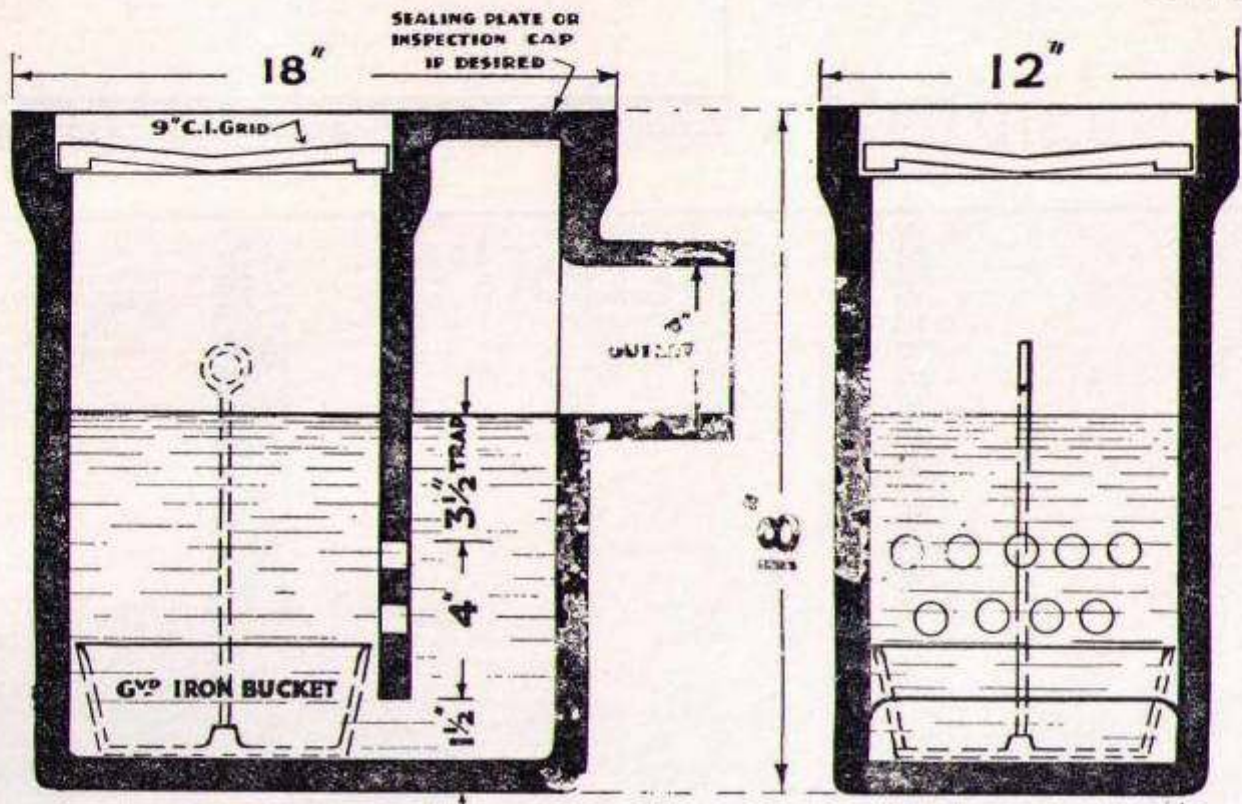

SECTION A.A.

SECTION B.B.

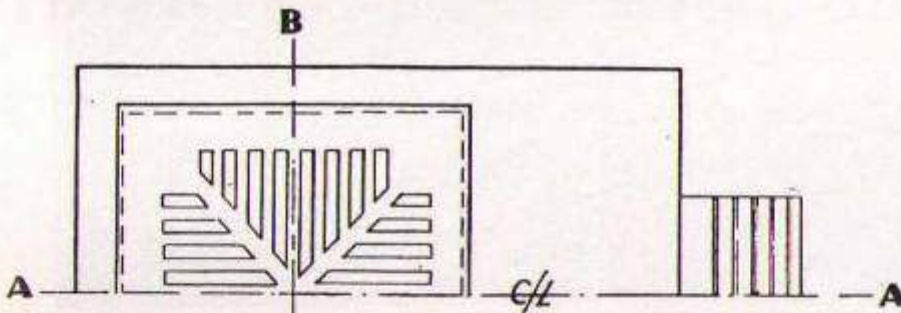

B
HALF PLAN

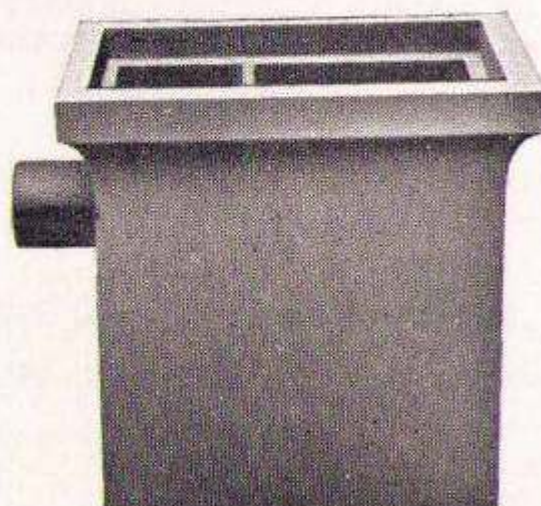

No. 1382

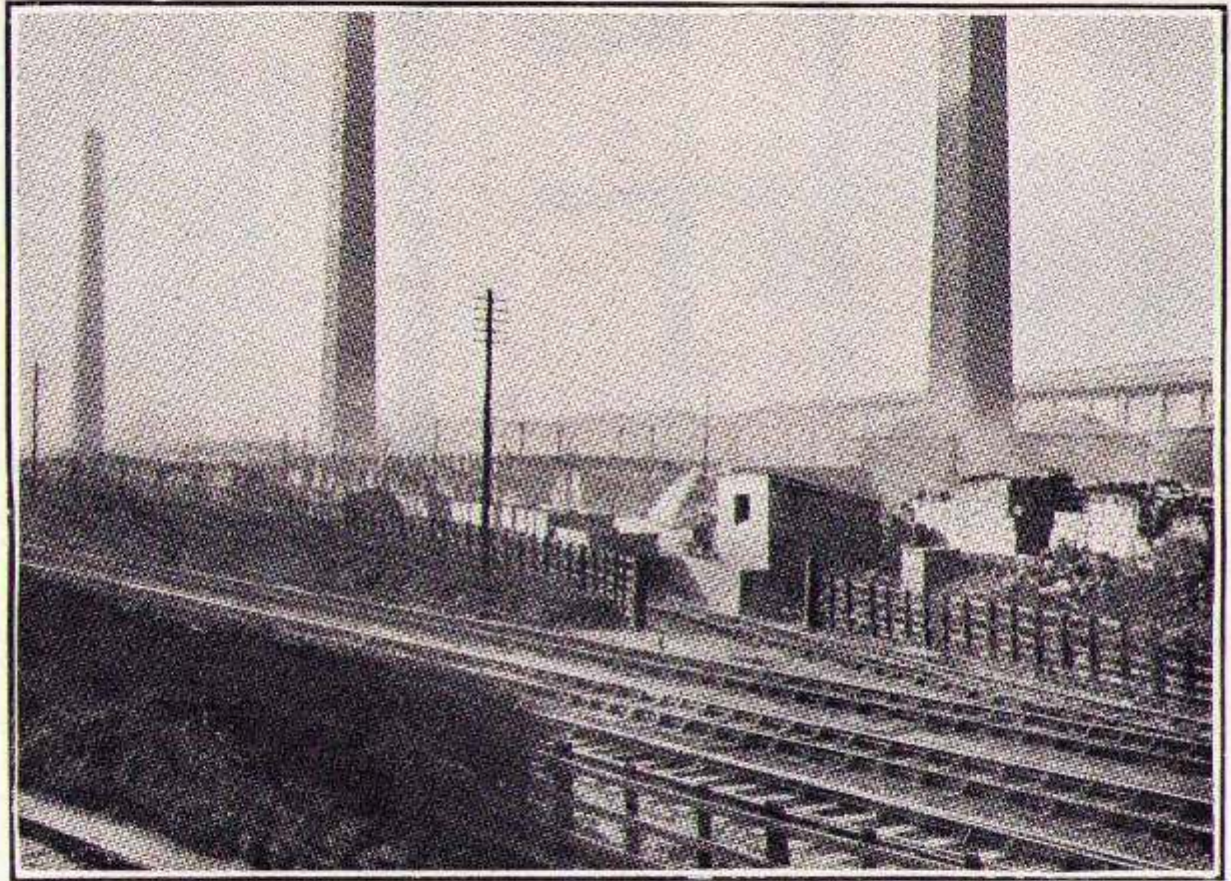

*Siding connection to the
Main Line*



Salt-Glazed Ware Drainage Details

—::—

THE FOLLOWING ILLUSTRATIONS
ARE REPRODUCED BY PERMISSION
OF THE
MINISTRY OF WORKS
WHO RESERVE THE RIGHT
TO ALTER THE NUMBERS OR DESIGNS
AT THEIR DISCRETION

—::—

**Delivery of Salt-Glazed Ware Drainage Fittings
can generally be effected from stocks**

SALT GLAZED WARE DRAINAGE DETAILS M.O.W. SHEET 1/s.

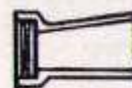
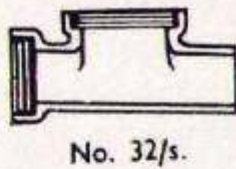
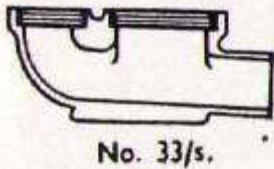
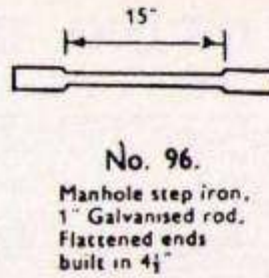
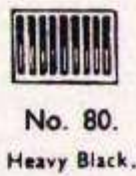
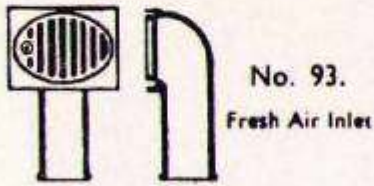
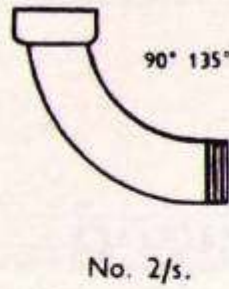
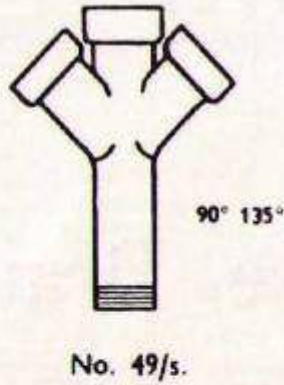
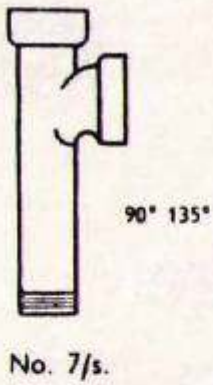

Taper Pipe	2" to 3"
Level Invert	2" " 4"
	3" " 4"
	4" " 6"
	6" " 9"
	9" " 12"

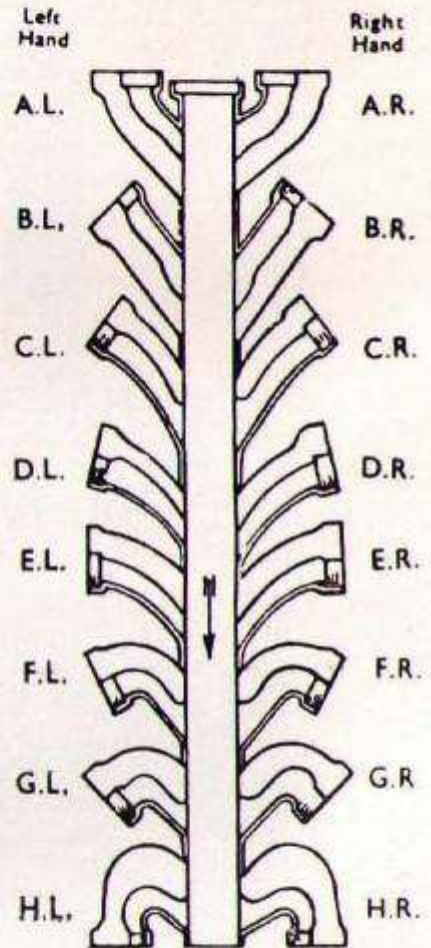

PLAN.
CURVED
CHANNEL BENDS
Three Quarter Section

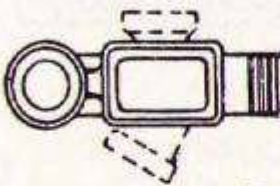

R. W. SHOES

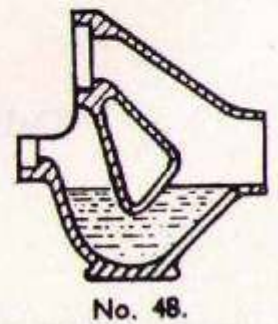
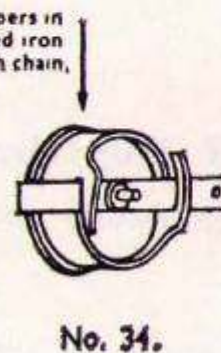
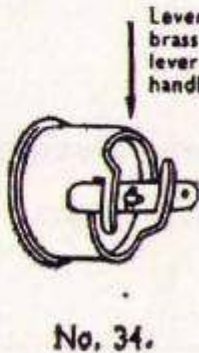

Lever locking stoppers in brass with galvanised iron lever complete with chain, handle and staple.

SALT GLAZED WARE DRAINAGE DETAILS M.O.W. SHEET 2/s.

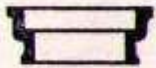

35/C.I. 3 inches.

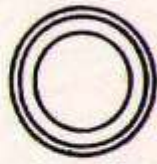

No. 17.



No. 18.

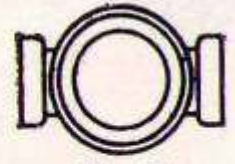

No. 19.

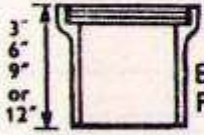

EXTENSION
PIECE.

No. 17/s.



No. 20.

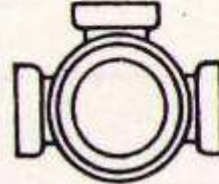

No. 21.



No. 22.



INLET
PIECE.

Access if
required.

No. 22/s.



No. 23.

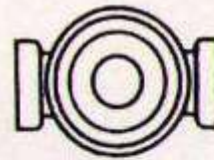

No. 24.



No. 24a.



No. 27/s.



REVERSIBLE
TOP
GULLY.

ENSEMBLE.



No. 25.



No. 26.

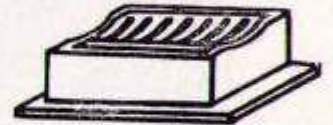

No. 104.

No. 35/C.I.



No. 13/s.



No. 14/s.



No. 51.
Heavy black.
Weight 18 lbs.

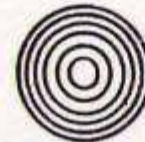

No. 52.
Extra
heavy.



No. 102.

Section

Plan

Fitted with
2 gunmetal
screws.

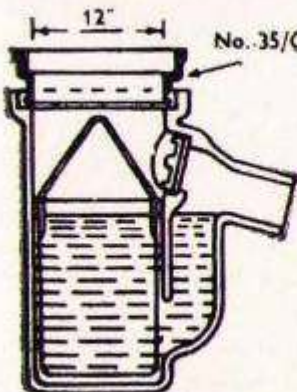

No. 30/s.

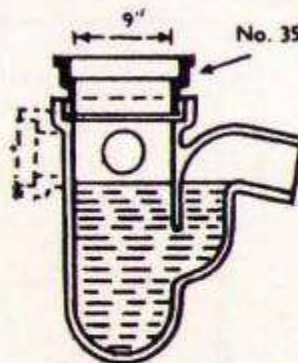

No. 28/s.

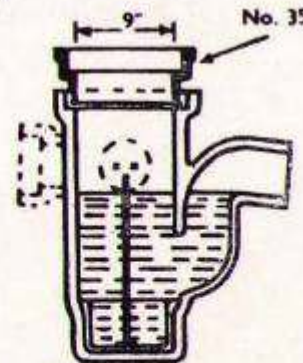

No. 59/s.

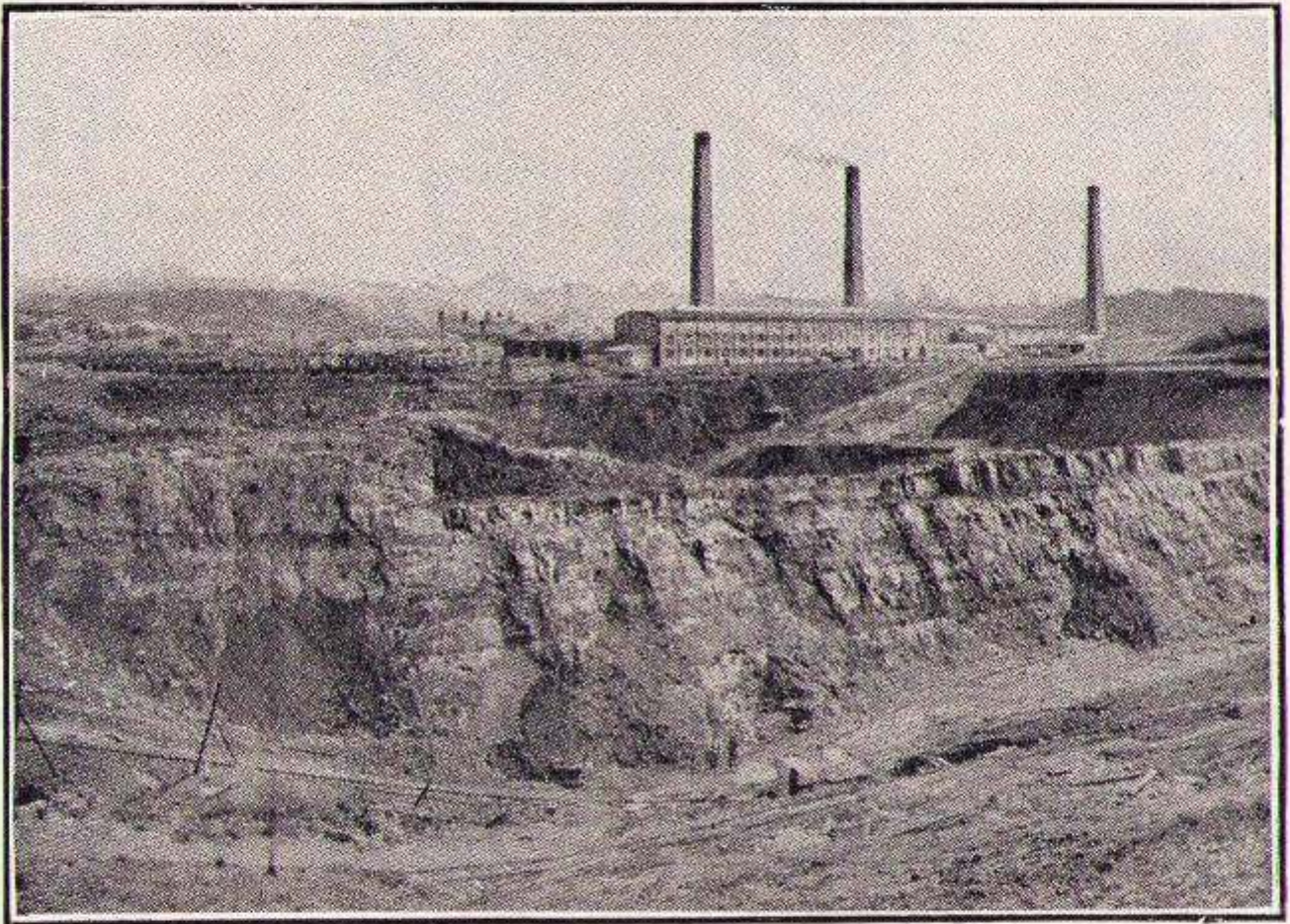

Part of the Clay Beds ●



STREET GULLIES
BLOCK TRAPS, FLAP VALVES,
INVERT and JUNCTION BLOCKS,
AIR BRICKS, FLUE LININGS,
HORSE MANGERS, CATTLE TROUGHS,
etc., in Salt-Glazed Stoneware



Improved Street Gullies in Salt-Glazed Stoneware

CIRCULAR ROAD GULLIES

12", 15" and 18" diameter

4", 6" or 9" Outlets

24" to 54" Deep with P. Q or Rodding Outlets

No. 1400

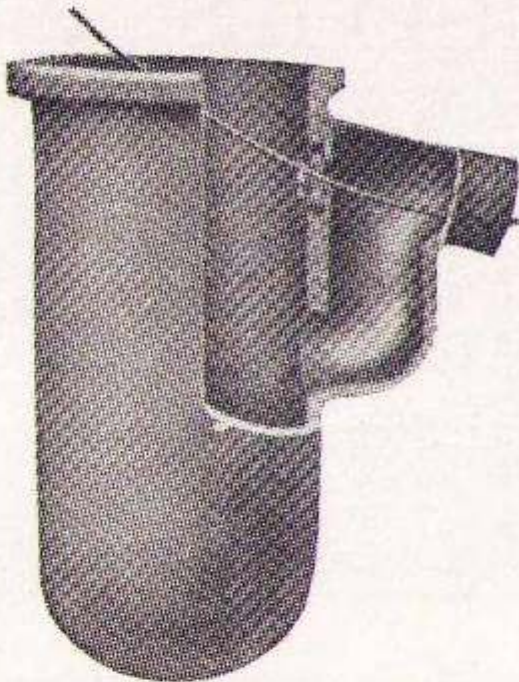

No 1401



Improved Street Gullies in Salt-Glazed Stoneware

THE SIMPSON No. 1403

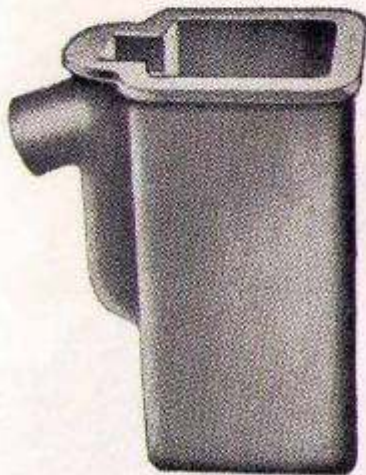

SIMPSON'S
GULLIES

- 15" × 12" × 24"
- 15" × 12" × 30"
- 15" × 12" × 36"
- 18" × 15" × 30"
- 18" × 15" × 36"
- 18" × 15" × 42"

Inside Measurements

No. 1404

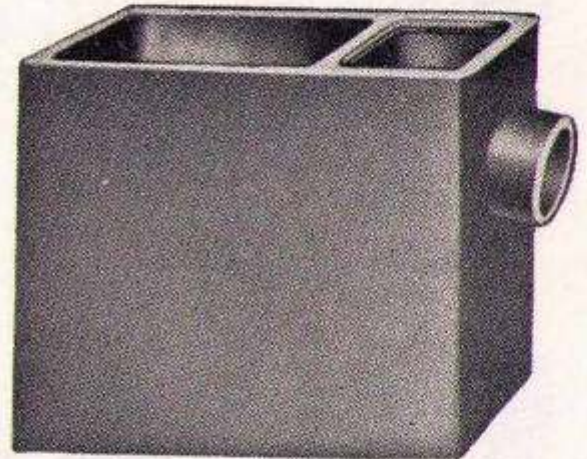

THE RADCLIFFE No. 1405



THE
SHARP
No. 1406

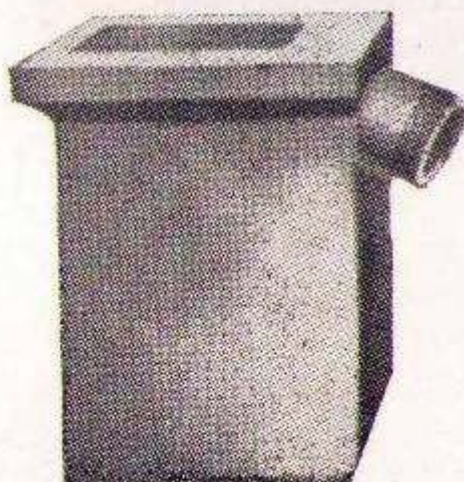

THE
LANCASTER
No. 1407

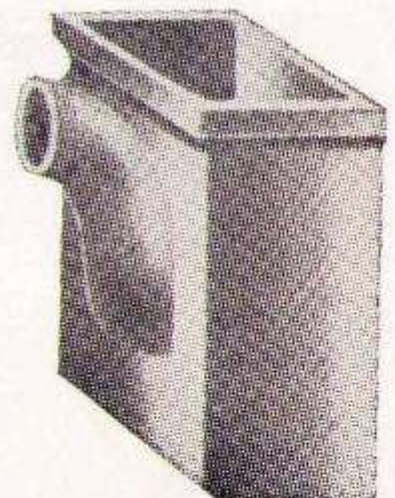



IMPROVED STREET GULLIES

No 1408

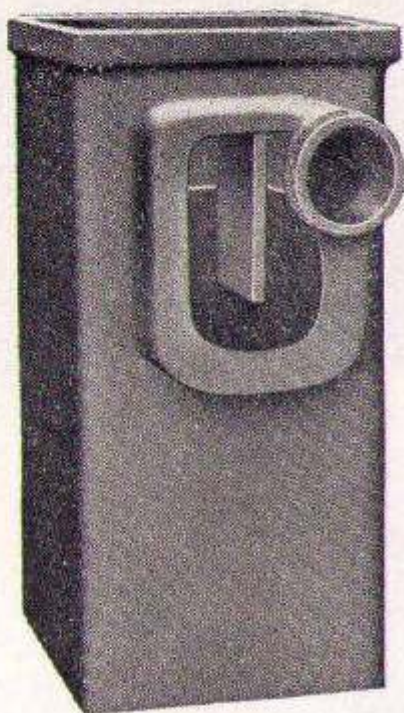

No 1409

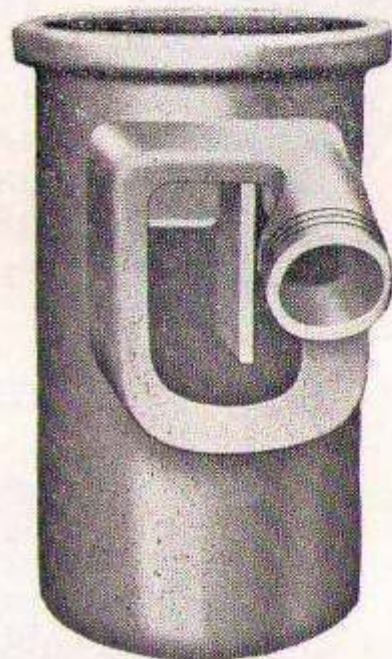

Fitted with galvanised Sealing-Plate and Frame
unless otherwise ordered.

FRESH AIR INLETS FOR FILTER BEDS

No 1410



STONEWARE LIMITED



**Invert Blocks, Junction Blocks, Pig Troughs,
Cattle Troughs, Mangers in Salt-Glazed Stoneware**



No 1411

No 1412

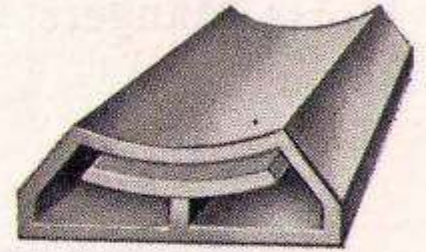

No. 1413

No. 1414

No. 1415

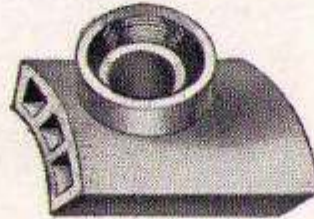
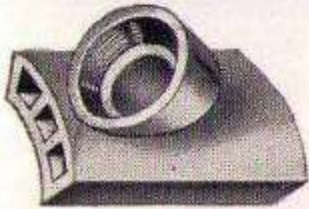

No. 1416

No. 1417

No. 1418

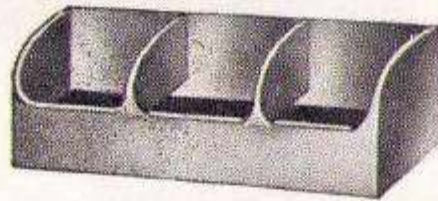

No. 1419

No. 1420

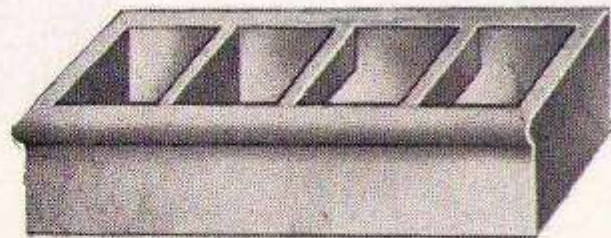

STAFFORDSHIRE BLUE OR RED GOODS

No. 1421

No. 1422

No. 1423



For Illustrations of Blue Metallic Goods see pages 85—92



STONEWARE LIMITED

Horse Mangers, Cattle Troughs, in Salt-Glazed Stoneware
and Garden Edging

No 1424



No 1425



No 1426



No 1427



No 1428



Red, Blue, Buff or Salt-Glazed

No 1429





AirBricks, Chimney Cones, Chimney Partitions,
Flue Linings.

AIR BRICKS

No 1430



No 1431

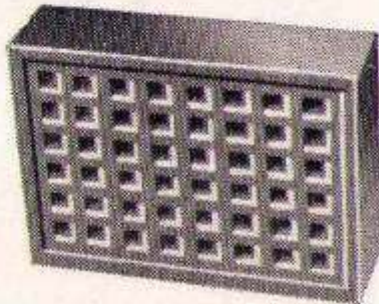

No 1432



FLUE LININGS

No 1433

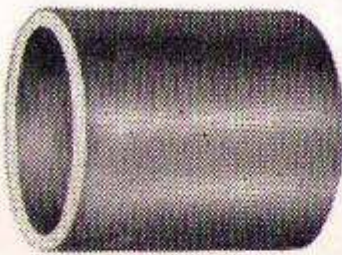

No 1434

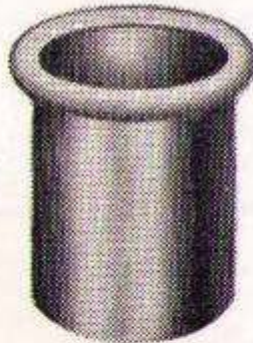

No 1435

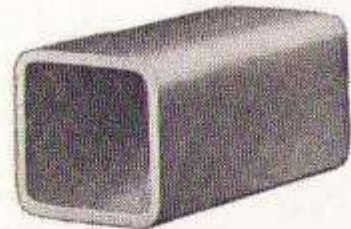

No 1436



No 1437





Air-Brick
Extension
for
Cavity
Walls

Dean's Patent
No. 407789

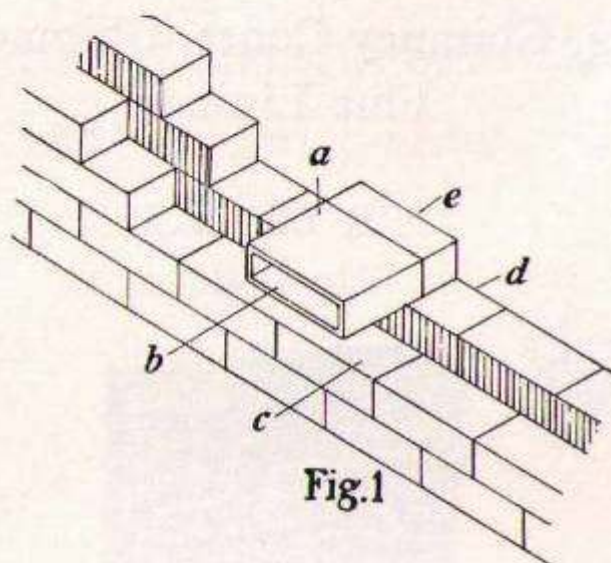

Fig.1

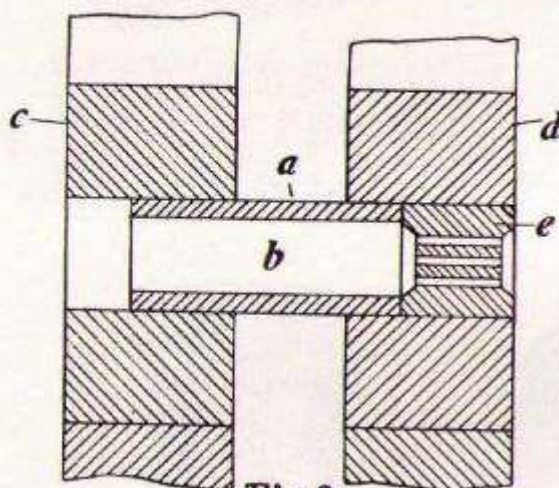

Fig.2

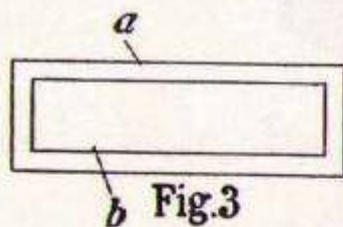

Fig.3

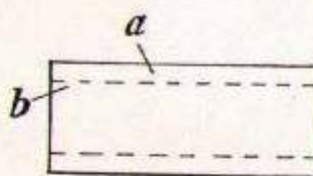

Fig.4

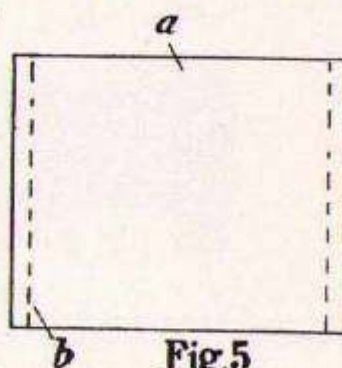

Fig.5

Standard Sizes
9" x 3", 9" x 6"
9" x 9"
Other Sizes to
Order



CHIMNEY TOPS



Red, Buff, Blue, or Salt-Glazed Chimney Pots.

No. 1433

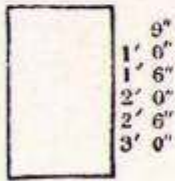

No. 1434

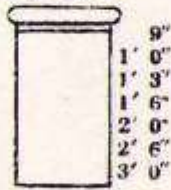

No. 1452



No. 1455

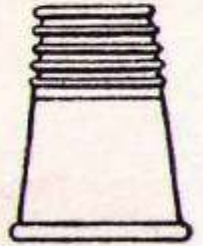

No. 1456

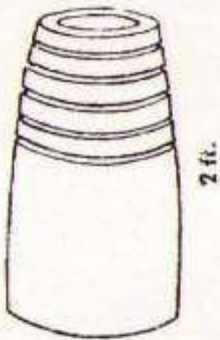

No. 1457

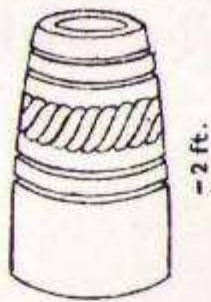

No. 1458



No. 1459

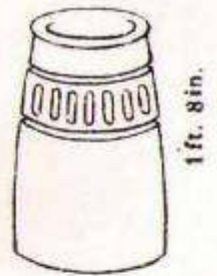

No. 1460



No. 1461

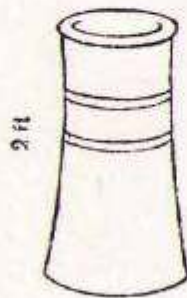

No. 1462

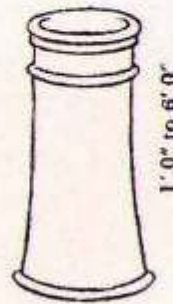

No. 1463

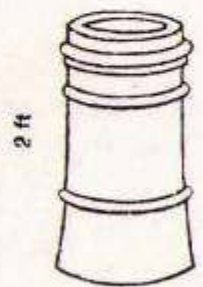



Red, Buff, Blue, or Salt-Glazed Chimney Pots.

No. 1438

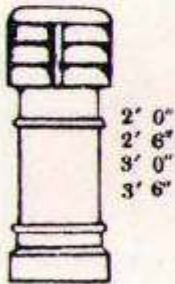

No. 1439

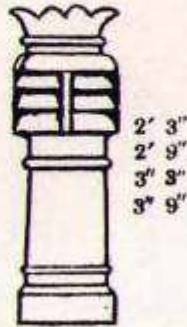

No. 1442

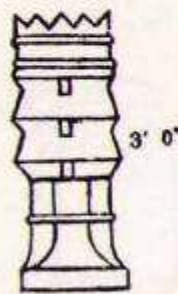

No. 1443

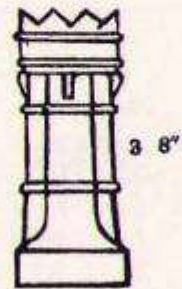

No. 1444

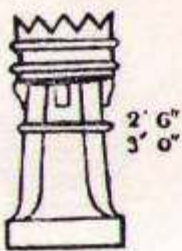

No. 1454

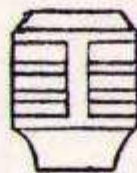

No. 1449



No. 1446

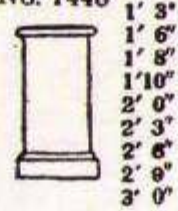

No. 1448

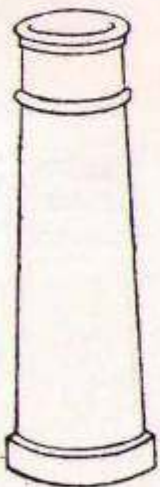

No. 1440

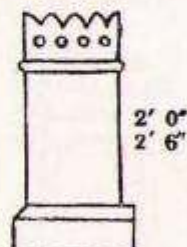

No. 1473

With 8 Pockets

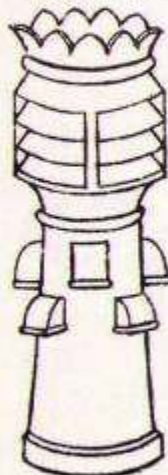

No. 1474

With 8 Pockets





Red, Buff, Blue, or Salt-Glazed Chimney Pots.

No. 1453



No. 1464

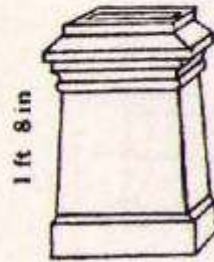

1 ft 8 in

No. 1465



2 ft 0 in.

No. 1466

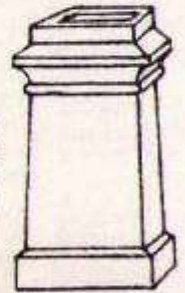

2 ft. 0 in.

No 1467



2 ft 6 in

No. 1450

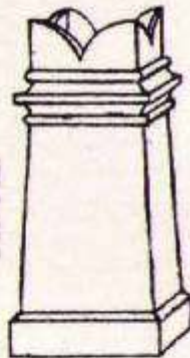

2 ft. 6 in.

No. 1468



2 ft. 6 in.

No. 1469

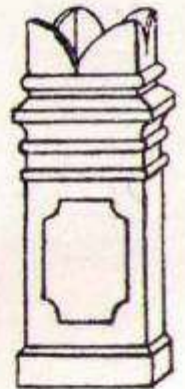

No. 1470

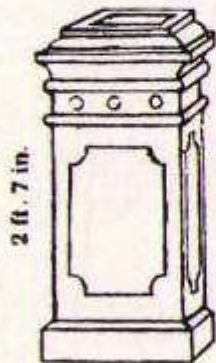

2 ft. 7 in.

No. 1451

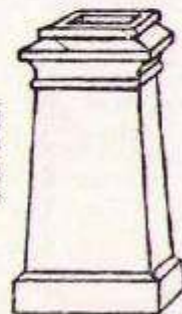

2 ft 2 in.

No. 1471

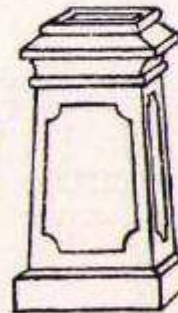

2 ft 2 in

No. 1472

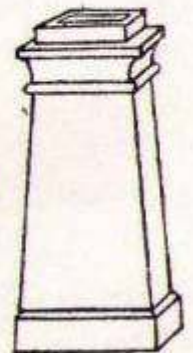

2 ft. 6 in

15x12 in



**IRON GRATINGS
MANHOLE COVERS
ETC.**



IRON GRATINGS, Etc.

Nos 1501



1502



1503



1504



1505



1506



1507



Nos 1508



1509



1510



1511



1512



1513



Nos 1514



1515



1516

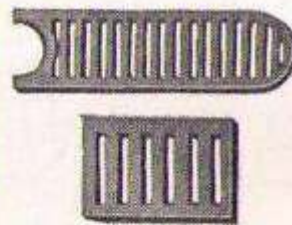

1517

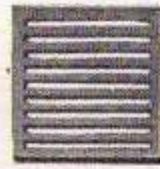

1518



No 1519

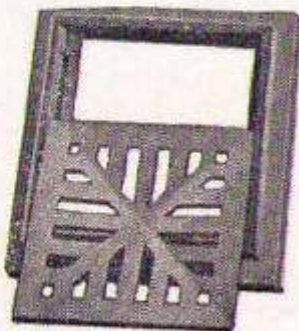

No 1520

No 1521

No 1522

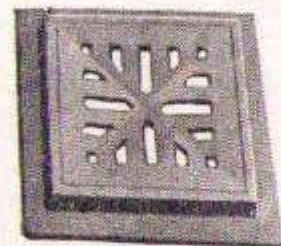



IRON GRATINGS, etc.

No 1523

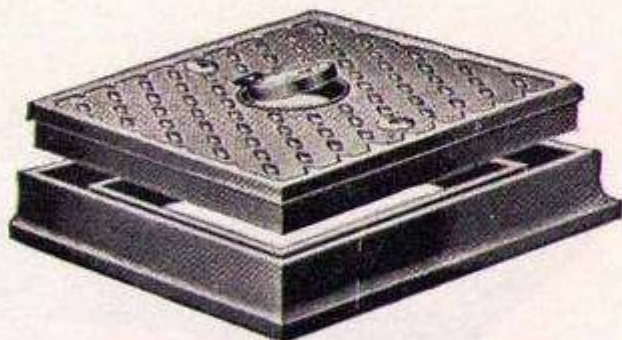

No 1524

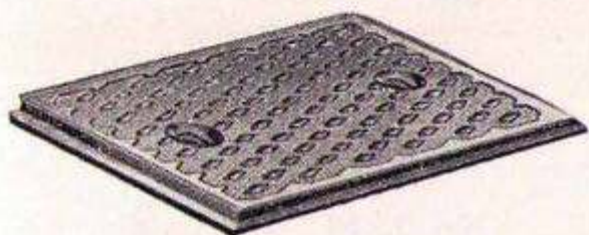

No 1525

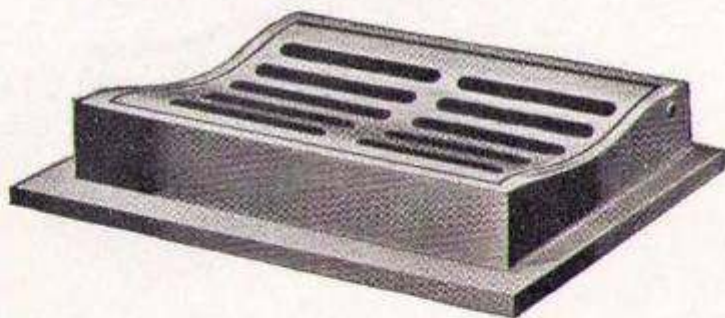

No 1526

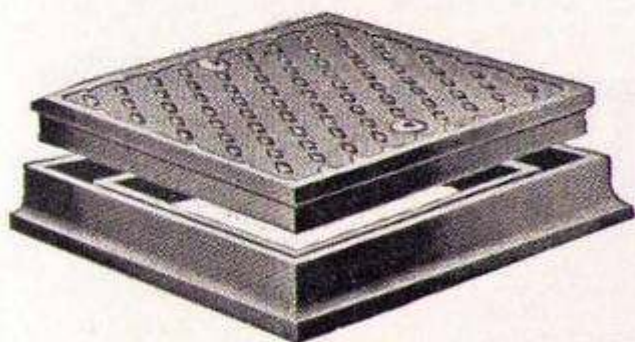



Sealing Plates, Grates, Manhole Covers, etc.

No 1527

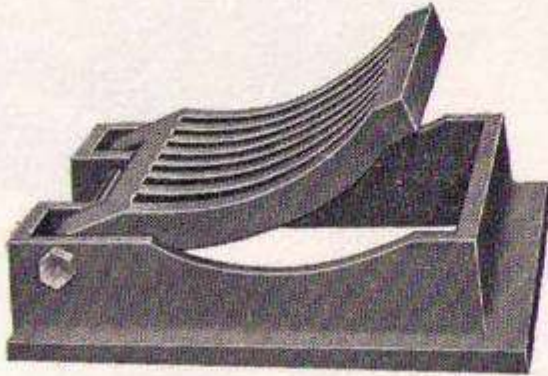

No 1528

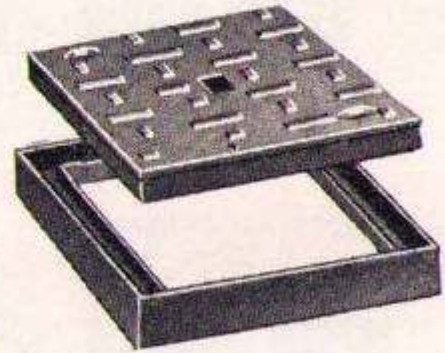

No 1529

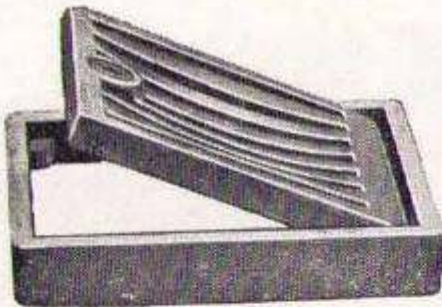

No 1530

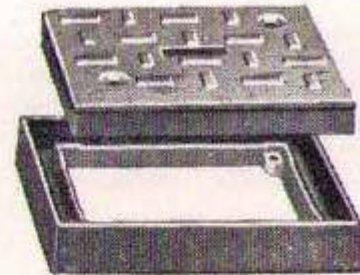

No 1531

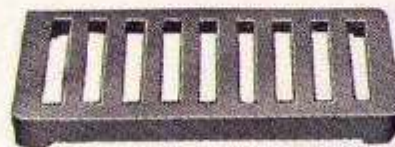



IRON GRATINGS, etc.

No 1532



No 1533

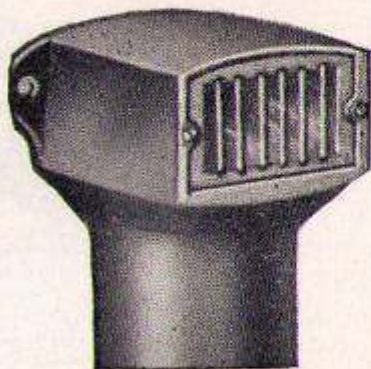

No 1535

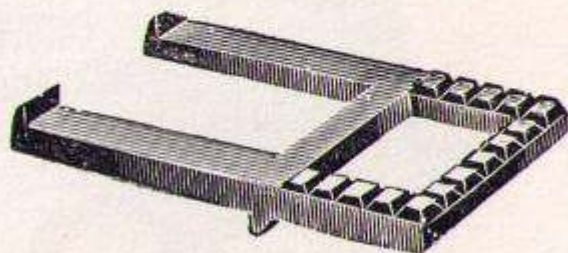

No 1534

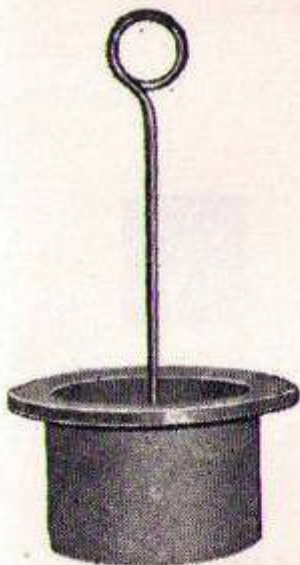

No 1536

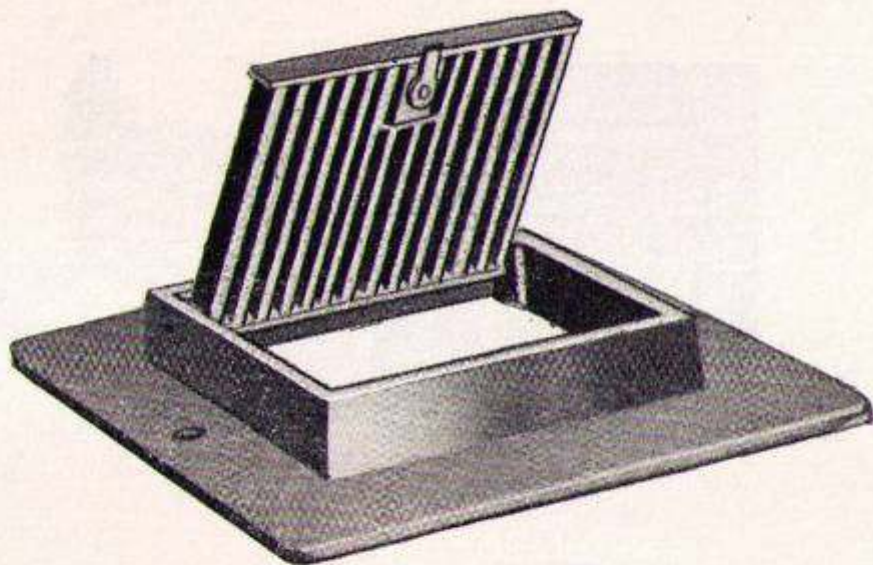

No 1537

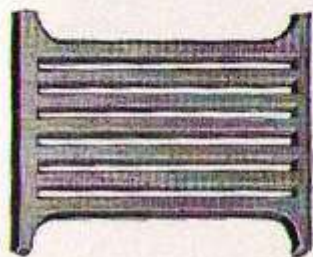

No 1538

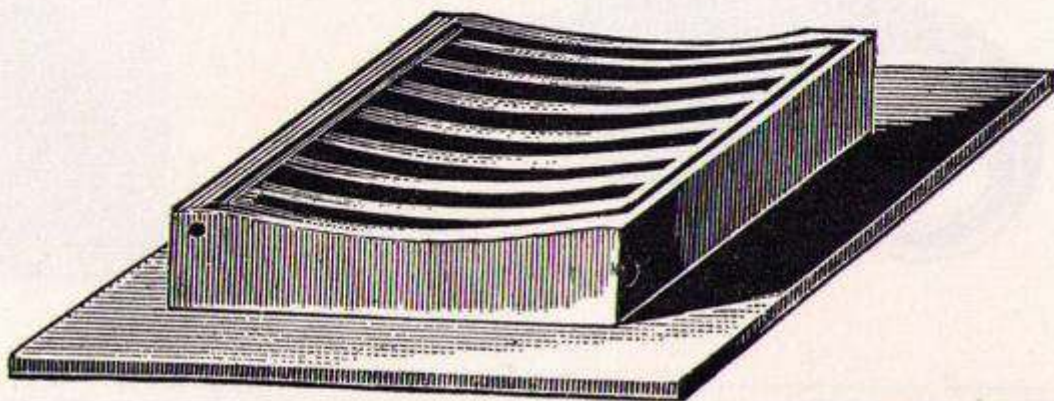



STONEWARE LIMITED

IRON GRATINGS, etc.

No 1539



STRAINER BUCKET

No 1540



No 1541

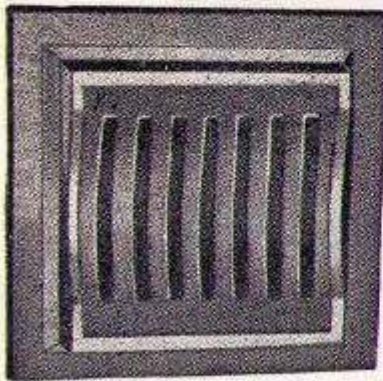

No 1542



No 1543

No 1544

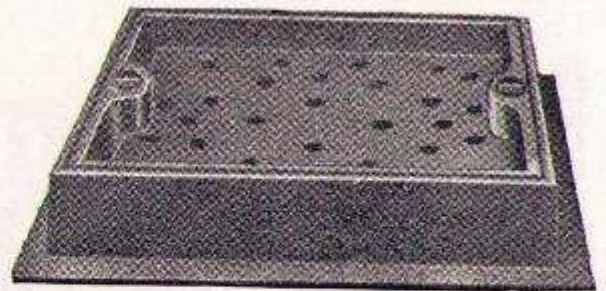
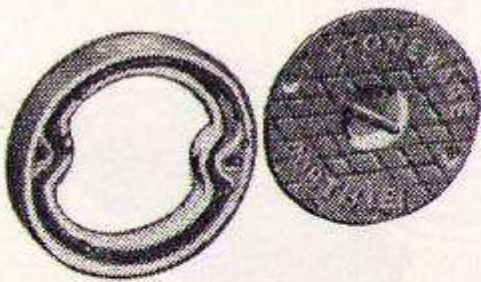



IRON GRATINGS etc.

No 1545

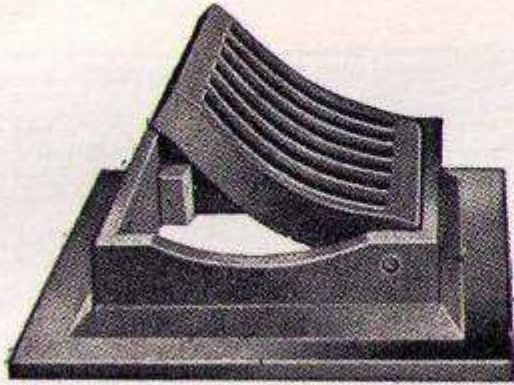

No 1546

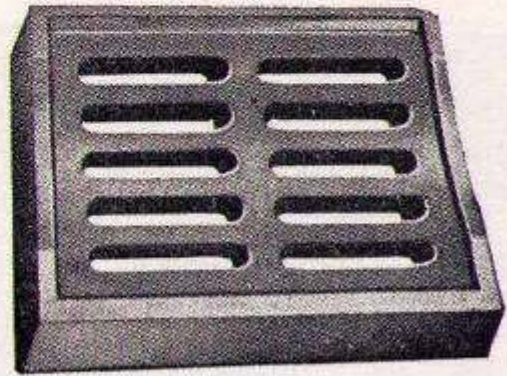

No 1547

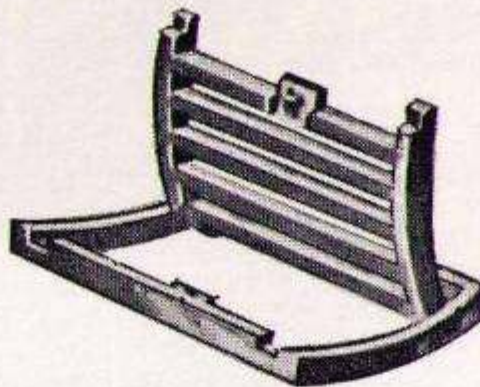

No 1548

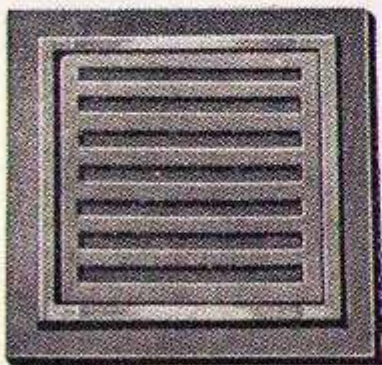

No 1549

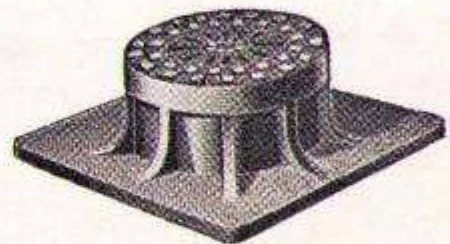

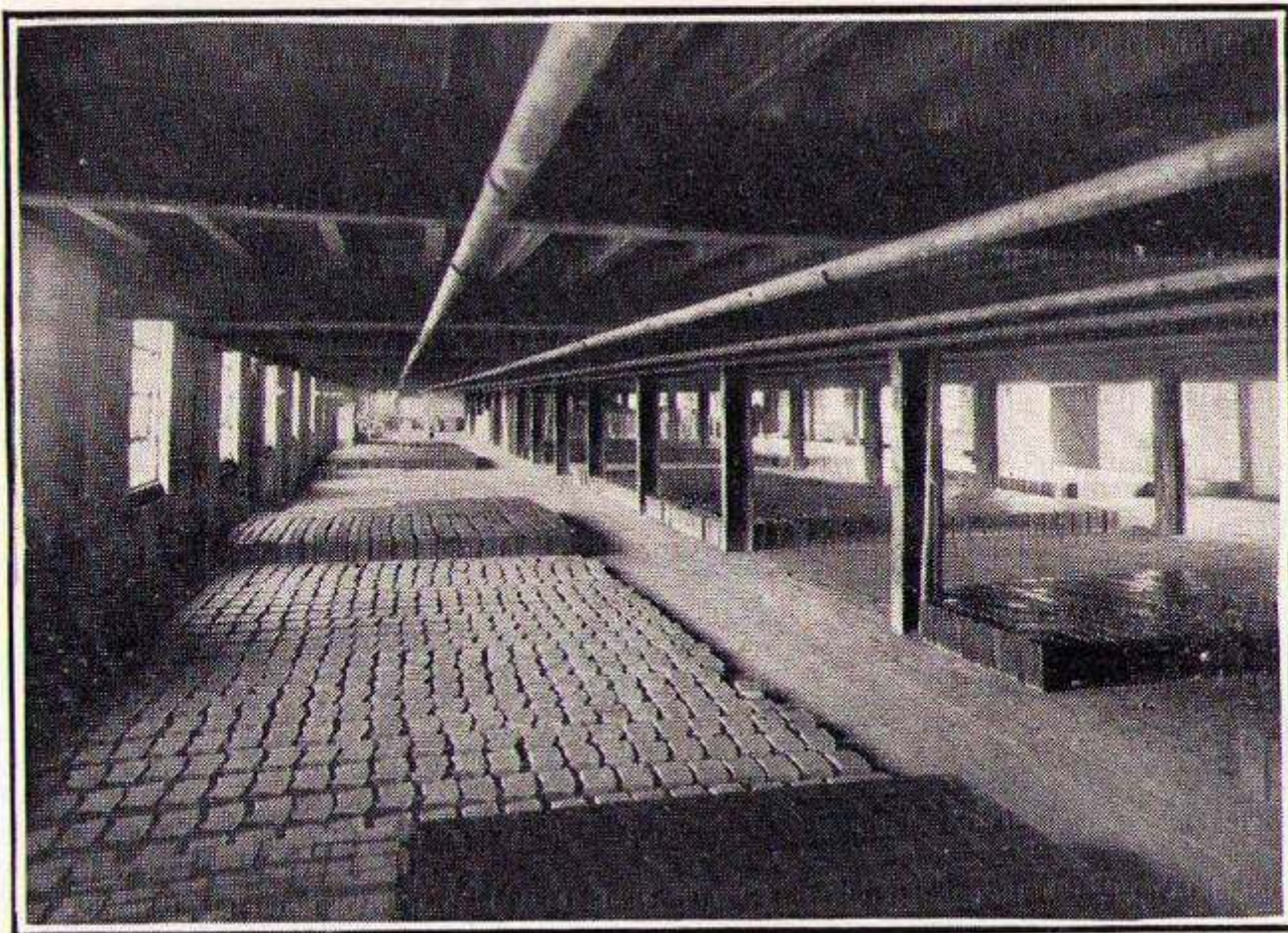

Bricks drying before Firing



**RED and BLUE
GOODS**



Red and Blue Goods.

901.

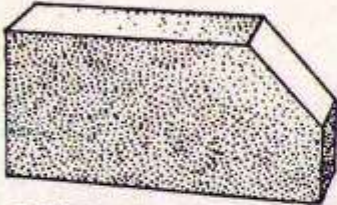

CANT. $9'' \times 4\frac{1}{2}'' \times 3''$ or $2\frac{3}{8}''$.

902.

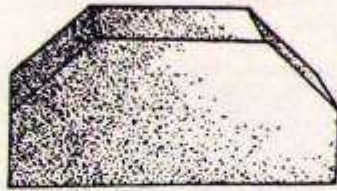

DOUBLE CANT.
 $9'' \times 4\frac{1}{2}'' \times 3''$ or $2\frac{3}{8}''$

903.

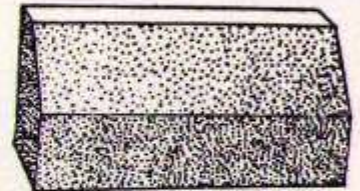

PLINTH STRETCHER.
 $9'' \times 4\frac{1}{2}'' \times 3''$ or $2\frac{3}{8}''$.

904.

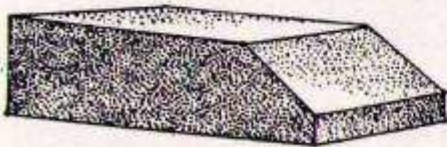

PLINTH HEADER.
 $9'' \times 4\frac{1}{2}'' \times 3$ or $2\frac{3}{8}''$.

905.

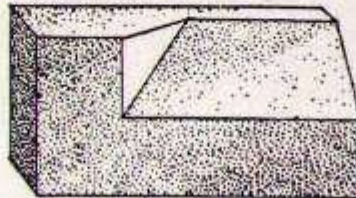

PLINTH, INTERNAL RETURN.
 $9'' \times 4\frac{1}{2}'' \times 3''$ or $2\frac{3}{8}''$

906.

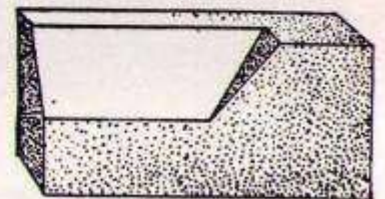

PLINTH, INTERNAL STOP.
 $9'' \times 4\frac{1}{2}'' \times 3''$ or $2\frac{3}{8}''$.

907.

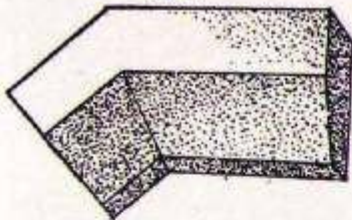

PLINTH, INTERNAL ANGLE.
Standard Angles 45° and 60°
 $2\frac{3}{8}''$ or $3''$ thick.

908.

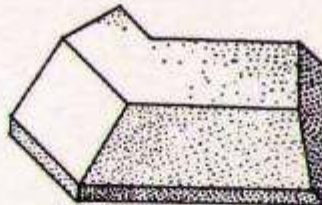

PLINTH, EXTERNAL ANGLE.
Standard Angles 45° and 60°
 $2\frac{3}{8}''$ or $3''$ thick.

909.

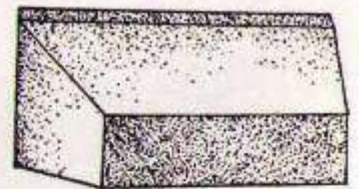

PLINTH, EXTERNAL RETURN.
 $9'' \times 4\frac{1}{2}'' \times 3''$ or $2\frac{3}{8}''$.

910.

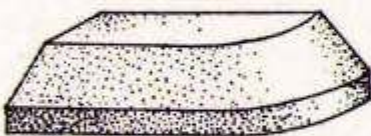

BULLNOSE PLINTH.
 $9 \times 4\frac{1}{2}'' \times 3''$ or $2\frac{3}{8}''$.

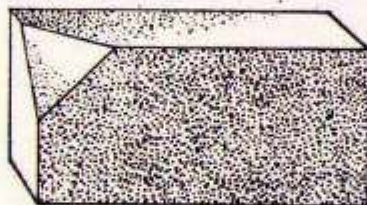

911—Cant or Plinth Stop.
912—Double Cant or Plinth Stop.
 $9'' \times 4\frac{1}{2}'' \times 3''$ or $2\frac{3}{8}''$.

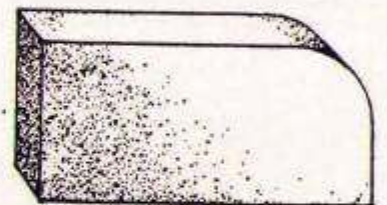

913—Single Bullnose, $1''$ radius.
914— " " $2\frac{1}{4}''$ "
915— " " $4\frac{1}{2}''$ "
 $9'' \times 4\frac{1}{2}'' \times 3''$ or $2\frac{3}{8}''$

Sizes given are Standard, but bricks can be supplied to any thickness to suit requirements.

Nos. 907 and 908 can also be made specially to any angle required.



Red and Blue Goods.

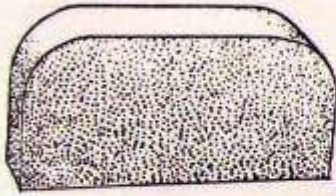

916—Double Bullnose, 1" radius,
917— " " " 2 1/2" "
918— " " " 4 1/2" "
9" x 4 1/2" x 3" or 2 3/8"

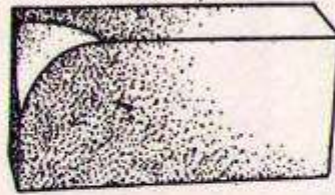

919—Single Bullnose Stop 1" radius.
920— " " " 2 1/2" "
921— " " " 4 1/2" "
9" x 4 1/2" x 3" or 2 3/8"

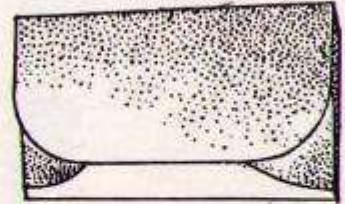

922—Double Bullnose stop 1" rad.
923— " " " 2 1/2" "
924— " " " 4 1/2" "
9" x 4 1/2" x 3" or 2 3/8"

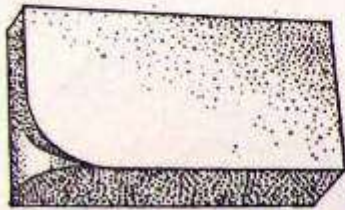

925—Bullnose Internal Return, 1" Rad.
926— " " " 2 1/2" "
9" x 4 1/2" x 3" or 2 3/8"

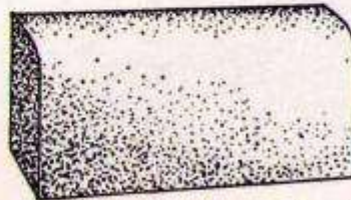

927—Bullnose Stretcher on Flat, 1" Rad.
928— " " " 2 1/2" "
9" x 4 1/2" x 3" or 2 3/8"

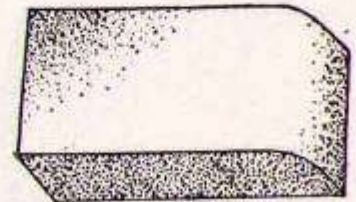

929—Bullnose Header, on flat, 1" Rad.
930— " " " 2 1/2" "
9" x 4 1/2" x 3" or 2 3/8"

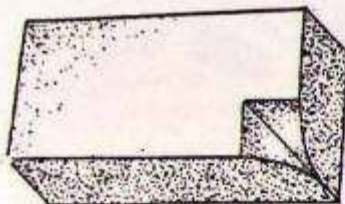

931—Bullnose Int. Return on flat, 1" rad.
932— " " " 2 1/2" "
9" x 4 1/2" x 3" or 2 3/8"

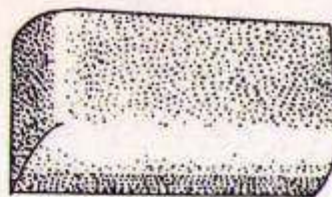

933 - Bullnose Ext. Ret. on flat, 1" rad.
934 - " " " 2 1/2" "
9" x 4 1/2" x 3" or 2 3/8"
935—Double Bullnose Ext. Ret. on flat, 1" rad.
936— " " " 2 1/2" "
9" x 9" x 3" or 2 3/8"

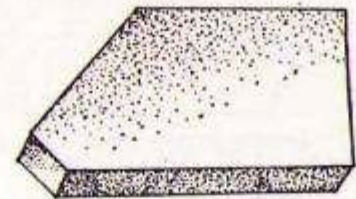

937—Squint Brick, 45°.
938— " " " 60°.
9" x 4 1/2" x 3" or 2 3/8"

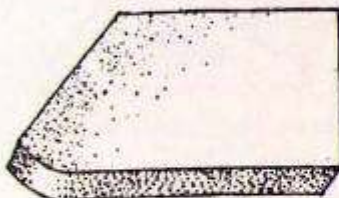

939 - Bullnose Squint.
9" x 4 1/2" x 3" or 2 3/8"



940 - Bird's Mouth.
9" x 4 1/2" x 3" or 2 3/8".
Angle to suit requirements.

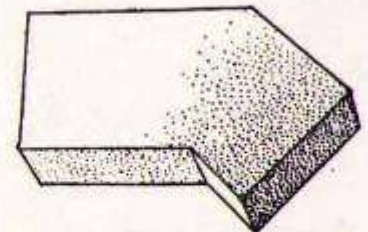

941—Angle Brick or Dogleg, 45°.
942— " " " 60°.

Nos. 933, 934, 935 and 936 can be made with rounded angle if required.

See also Nos. 970—976 inclusive for special Bullnose Angles.

Sizes given are Standard, but bricks can be supplied to any thickness to suit requirements.

Nos. 937, 938, 941, 942 can be made to any special angle.



Culverts and Chimney (or Well) Brick made to any radius.

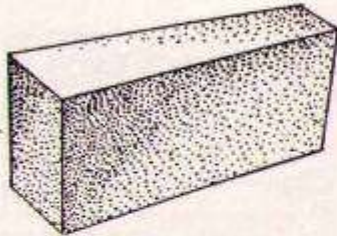

943—Culvert Stretcher.
9" long \times 4½" deep.

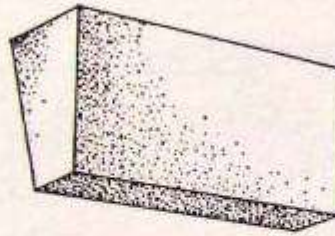

944—Culvert Header.
9" long \times 4½" deep.

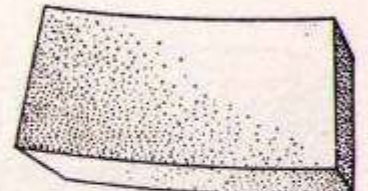

945—Chimney (or Well) Stretcher.
9" long outside \times 4½" \times 3" or 2½".

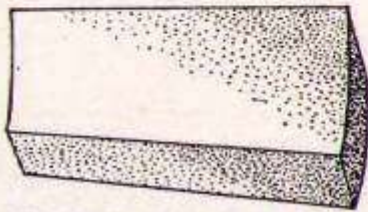

946—Chimney (or Well) Header.
9" long \times 4½" outside \times 3" or 2½".

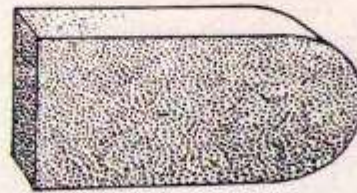

947—Bullnose on End (Cownose).
9" \times 4½" \times 3" or 2½".
Standard lengths 2½", 3", 6", 9" and 12".

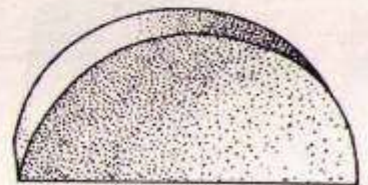

948—Half-moon Coping.
9" \times 4½" \times any workway required.



949—9" \times 3" Air Brick. 3" deep.



950—9" \times 6" Air Brick. 3" deep.

Air Bricks also made in the following sizes: 9" \times 9", 12" \times 9", 12" \times 12".

Air Brick made in three colours: red, blue, or buff.

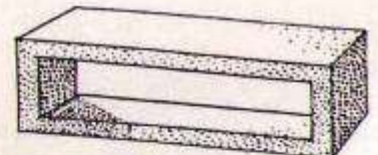

951 Air Brick Extension Piece.
9" \times 3" or 9" \times 6" by any required length.

Extension Pieces 951 made in red.

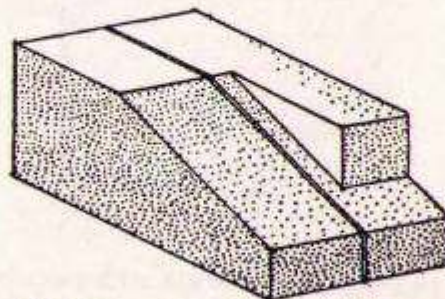

952—Example of Window Cill Brick and Stop. Can be supplied to any size or specification required.



Copings.

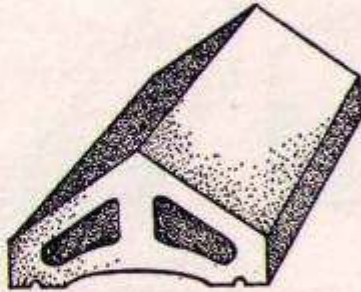

953—Saddle Back Coping.
12"X12"X6".

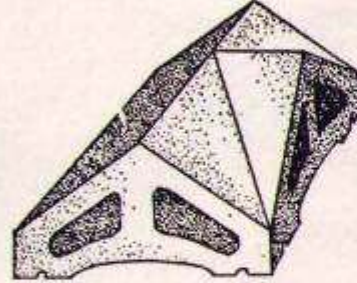

954—Tee Piece.
12"X12"X6".

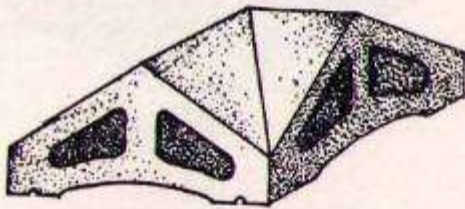

955—Square Angle.
12"X12"X6".

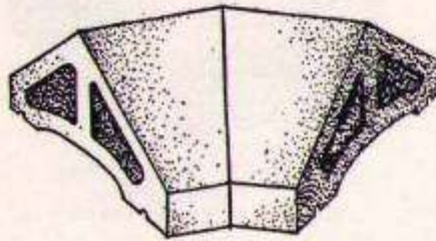

956—Octagonal Angle.
45°.

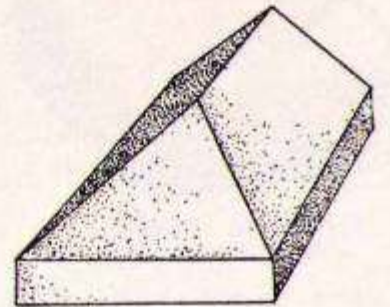

957—Stop End.
— 12"X12"X6".

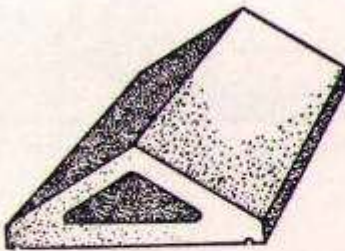

958—Saddle-back Coping.
12"X12"X4 1/2".

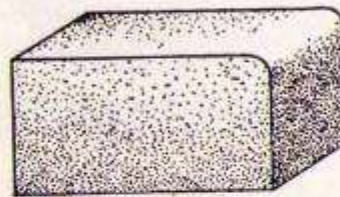

963—Single Bullnose Coping.

9"X6"X6, 12"X6"X6, 14"X6"X6,
16"X6"X6, 18"X6"X6, 20"X6"X6, Standard Sizes.

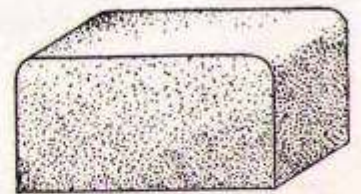

967—Double Bullnose Coping.
Sizes and Angles as Single Bullnose.

- 959—Tee Piece as for 12" X 6"
- 960—Square Angle do. do.
- 961—Octagonal Angle do. do.
- 962—Stop End do. do.

- 964—External Angle to Single Bullnose.
- 965—Internal do. do. Coping.
- 966—Stop do. do. do.

968—Double Bullnose Coping
Stop.

Saddle-back Copings can also be supplied 9" X 6" X 3" for 4 1/2" wall together with

Specials as above illustrations.



COPINGS. - continued.

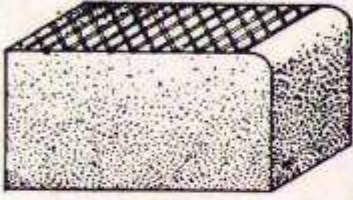

969 - Chequered Platform Coping.
9" x 6" x 6", 12" x 6" x 6", 14" x 6" x 6",
16" x 6" x 6", 18" x 6" x 6".

Wedge Copings or any Special Copings made to order. Angles to Copings are as illustrations 970 - 976.

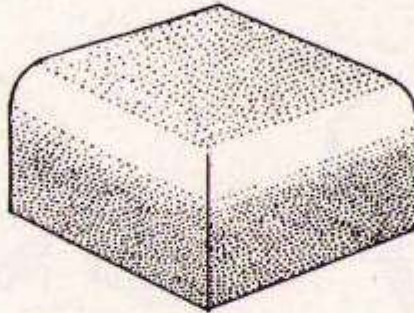

970 - Single Bullnose Stop or Angle.
9" x 9" x 4 1/2"
or to match Copings.

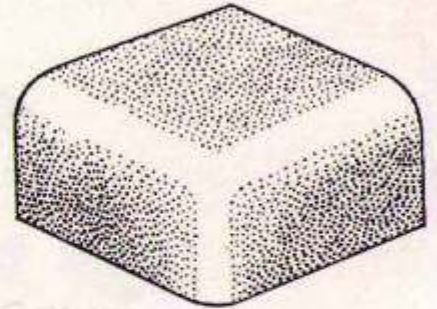

971 - Single Bullnose Stop or Angle
(with Rounded Corner).
9" x 9" x 4 1/2", or to match Copings.

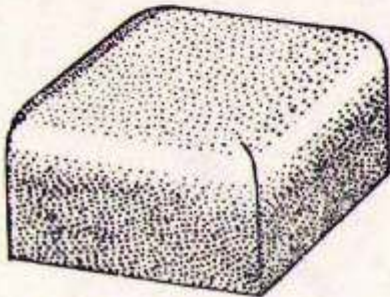

972 - Double Bullnose Stop.
9" x 9" x 4 1/2" or to match Copings.

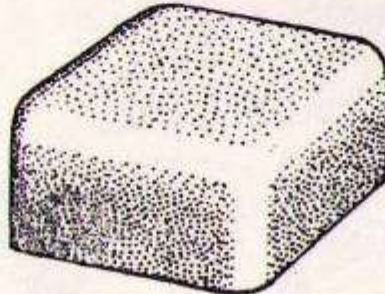

973 - Double Bullnose Stop.
(with Rounded Corners).
9" x 9" x 4 1/2", or to match Copings.

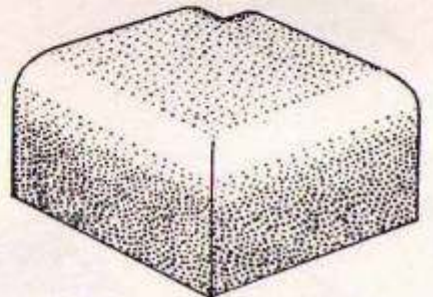

974 - Double Bullnose Angle.
9" x 9" x 4 1/2", or to match Copings.

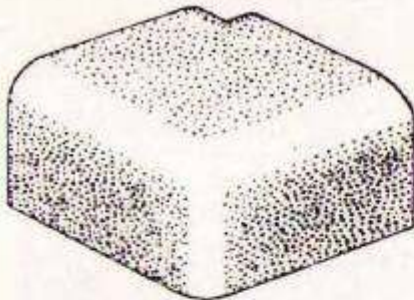

975 - Double Bullnose Angle
(with Rounded Corners).
9" x 9" x 4 1/2", or to match Copings.

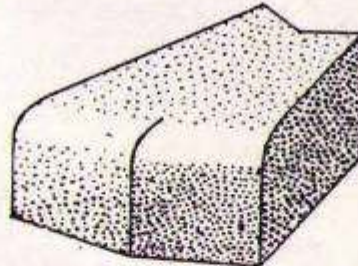

976 - Bullnose Octagonal Angle, 45°.
Sizes to suit Coping and Special Angle
as required.

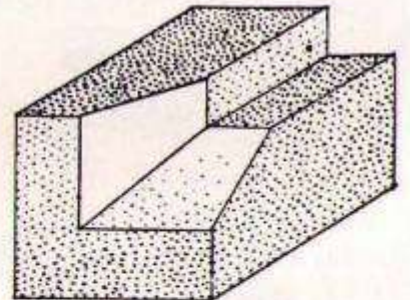

977 - Cant Jamb or Cill Mitre.
9" x 6" x 6".

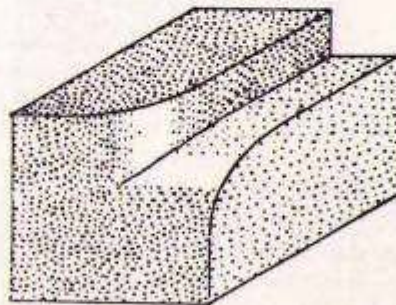

978 - Bullnose Jamb and Cill Mitre.
9" x 9" x 6".



Channels.

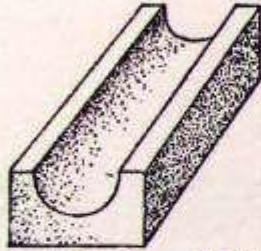

979 - Channel Brick.
 $9" \times 4\frac{1}{2}" \times 3"$ or $2\frac{3}{8}"$,
 $9" \times 6" \times 3"$,
 $12" \times 6" \times 3"$.

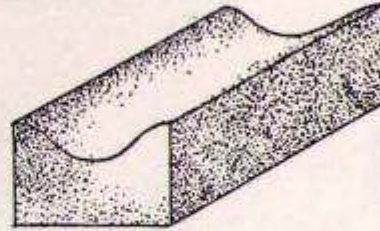

980 - Channel Brick.
 $9" \times 4\frac{1}{2}" \times 3"$ or $2\frac{3}{8}"$.

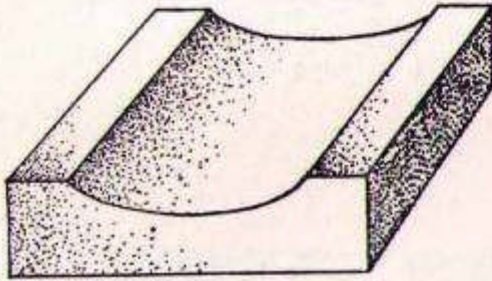

981 - Channel Brick.
 $9" \times 9" \times 3"$,
 $9" \times 12"$ workway $\times 3"$.

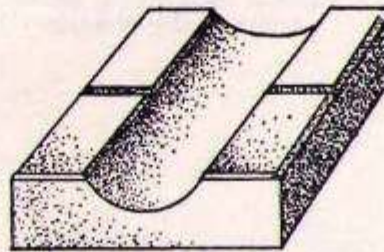

982 - Stable Brick Channel
 $9" \times 9" \times 3"$ or $2\frac{3}{8}"$.

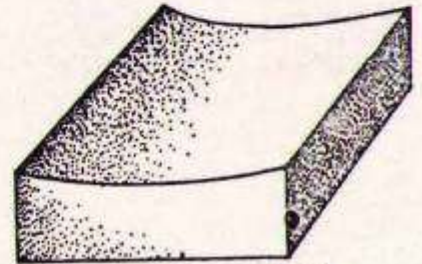

983 - Channel Brick.
 $16" \times 11" \times 4"$.

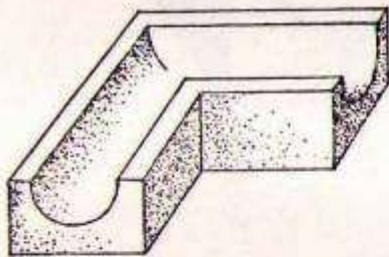

984 Channel Return.
 Made to match any pattern of Channel.

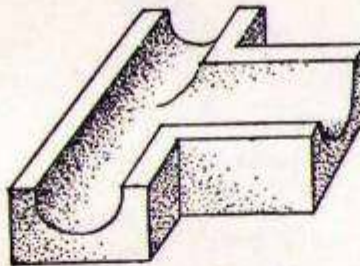

985 Channel Tee Piece.

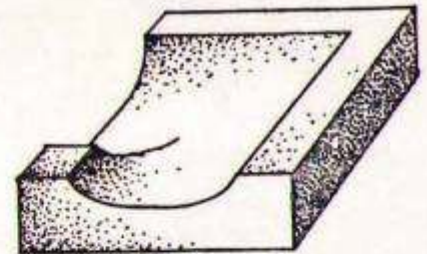

986 - Channel Return.
 $9" \times 9" \times 3"$.

Special Channel Bricks can be made to any specification.

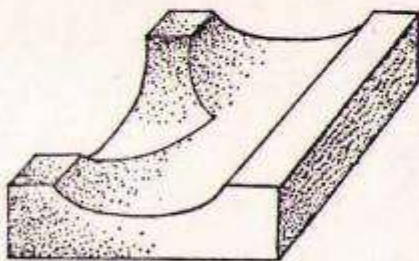

987 - Channel Tee Piece
 $9" \times 9" \times 3"$.

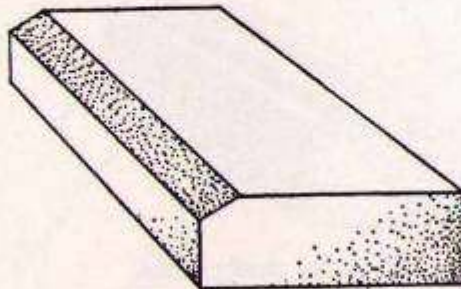

988 - Chamfered Kerb.
 $16" \times 9" \times 3"$,
 $16" \times 9" \times 4"$.

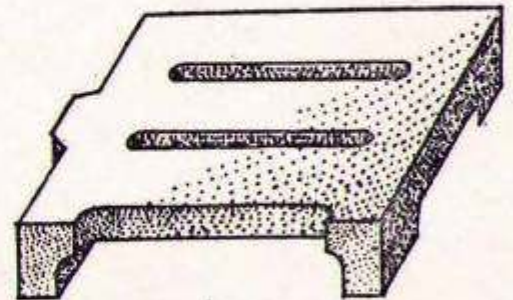

989 - Filter Bed Tile.
 $13" \times 12" \times 3"$ deep.
 Made in Salt-glazed Ware.

Nos. 984, 985, 986 and 987 Channel Specials can be made to suit any type of Channel brick.



Pavers.

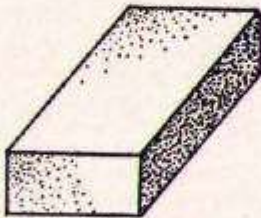

990—Paver.
 $9'' \times 4\frac{1}{2}'' \times 1''$, $10'' \times 5'' \times 1\frac{1}{2}''$,
 $9'' \times 4\frac{1}{2}'' \times 1\frac{1}{2}''$, $10'' \times 5'' \times 2''$,
 $9'' \times 4\frac{1}{2}'' \times 2''$, $12'' \times 6'' \times 2''$.

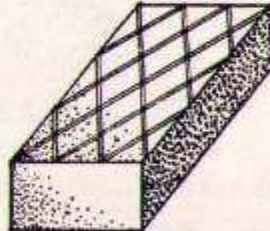

991—Chequered Paver.
Made in same sizes as 990 or
to any special thickness.

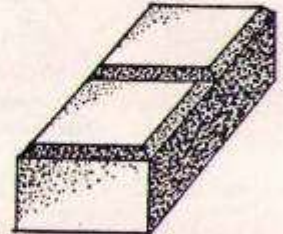

992—Stable Paver, 2-panel.
 $9'' \times 4\frac{1}{2}'' \times 2''$,
 $9'' \times 4\frac{1}{2}'' \times 2\frac{1}{2}''$,
 $9'' \times 4\frac{1}{2}'' \times 3''$.

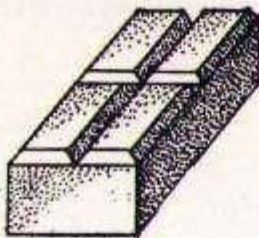

993—Stable Paver, 4-panel.
 $9'' \times 4\frac{1}{2}'' \times 2''$,
 $9'' \times 4\frac{1}{2}'' \times 2\frac{1}{2}''$,
 $9'' \times 4\frac{1}{2}'' \times 3''$.

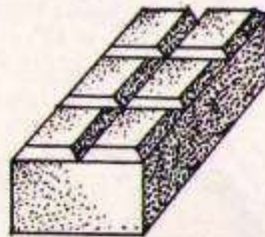

994—Stable Paver, 6-panel.
 $9'' \times 4\frac{1}{2}'' \times 2''$,
 $9'' \times 4\frac{1}{2}'' \times 2\frac{1}{2}''$,
 $9'' \times 4\frac{1}{2}'' \times 3''$.

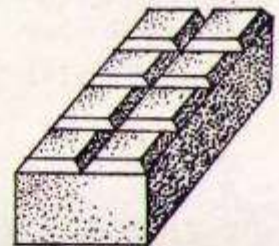

995—Stable Paver, 8-panel.
 $9'' \times 4\frac{1}{2}'' \times 2''$,
 $9'' \times 4\frac{1}{2}'' \times 2\frac{1}{2}''$,
 $9'' \times 4\frac{1}{2}'' \times 3''$.

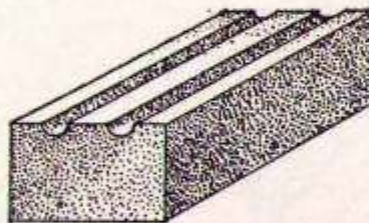

996—Fluted Stable Paver.
 $9'' \times 4\frac{1}{2}'' \times 2''$,
 $9'' \times 4\frac{1}{2}'' \times 2\frac{1}{2}''$,
 $9'' \times 4\frac{1}{2}'' \times 3''$.



Ridges.

Red, Blue, Buff, and Sand Faced.



997—Plain, Flat-pitch Ridge.

90°.
105°.
115°.
125°.

Made in 12" or 18" lengths.

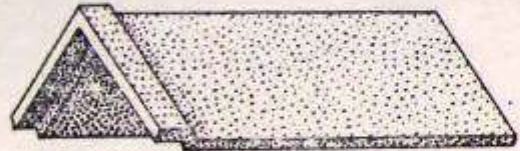

998—Capped Flat-pitch Ridge.

90°.
105°.
115°.
125°.

Made in 12" or 18" lengths.

RIDGE TILES and FLUE LININGS and can supply customers' requirements in
RED OR BRINDLED, BLUE OR BUFF.

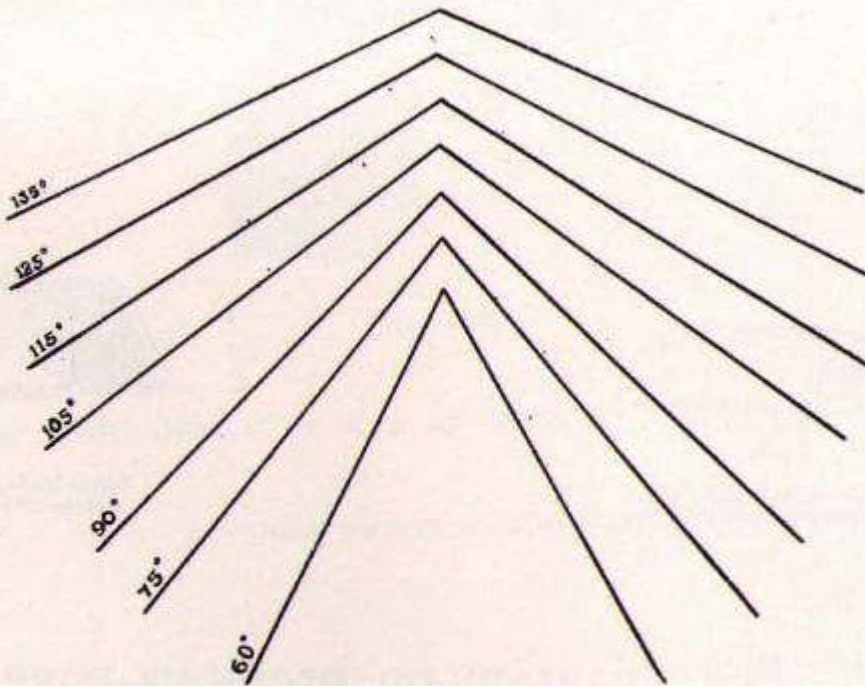



RIDGES.—continued.

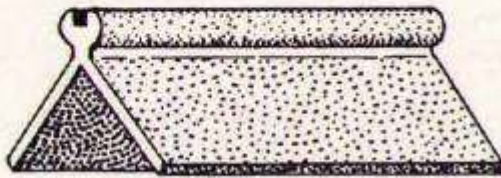

999.

Roll Top Ridge. 90°, 105°, 115°, 125°.
Made in 12" or 18" lengths.

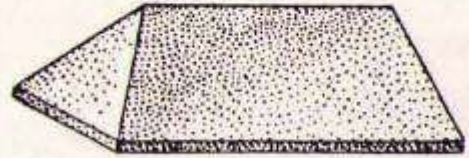

1000.

Ridge Tile Stop.
To match Nos. 997 and 998.



1001.

Plain Half-round Ridge.
90°—8" dia., 105°, 90°—9" dia.
Made in 12" or 18" lengths.



1002.

Capped Half-round Ridge. 90°, 105°.
Made in 12" or 18" lengths.



1003.

Half-round Ridge Stop.
To match Nos. 1001 and 1002.



1004.

Hogs-back Ridge Tile.
Made in 12" or 18" lengths.

See Diagram on previous page



Garden Tiles.

RED, BLUE, or SALT GLAZED.



1005.

Fluted Pattern.
7" x 7"

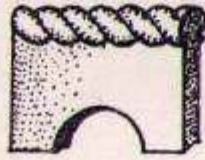

1006.

Rope Pattern. $1\frac{1}{2}$ " or 2" roll.
9" x 7"

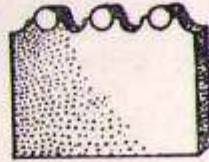

1007.

Nibbed Pattern.
9" x 8"

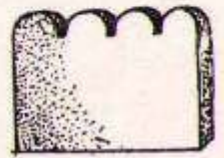

1008.

Arched Pattern.
9" x 8"

Gas Boiler Flue Brick.

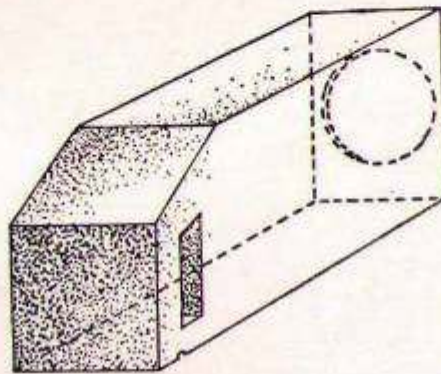

No. 1009

Dimensions: 11" x 6" x $4\frac{1}{2}$ " with a $2\frac{1}{4}$ " or 3" opening.

Other sizes supplied to order.

